

OPERATOR'S MANUAL

CRAFTSMAN®

10 in. TABLE SAW

Model No.
315.284610

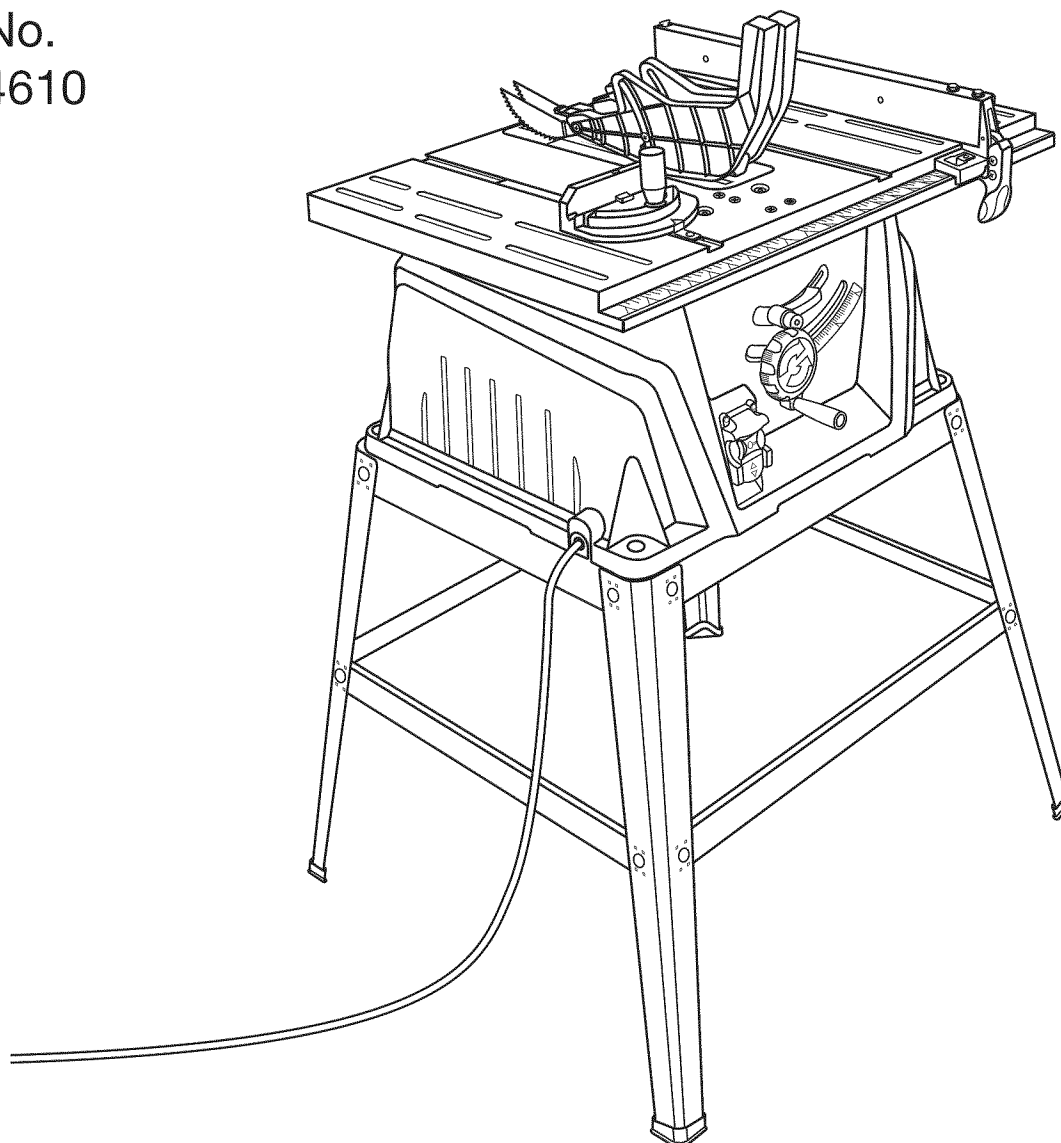

WARNING: To reduce the risk of injury, the user must read and understand the operator's manual before using this product.

Customer Help Line: 1-800-932-3188

Product distributed in the United States by Sears Brands Management Corporation
Hoffman Estates, IL 60179

Visit the Craftsman web page: www.sears.ca

988000-118
5-18-10 (REV:01)

Save this manual for future reference



TABLE OF CONTENTS

■ Introduction	2
■ Warranty	2
■ General Safety Rules	3-4
■ Specific Safety Rules	4-5
■ Symbols	6-7
■ Electrical	8
■ Glossary of Terms	9
■ Features	10-13
■ Tools Needed	13
■ Loose Parts	14-15
■ Assembly	16-22
■ Operation	23-35
■ Adjustments	36-38
■ Maintenance	38
■ Troubleshooting	39-40
■ Illustrated Parts List	41-48
■ Parts Ordering/Service	Back Page

INTRODUCTION

This tool has many features for making its use more pleasant and enjoyable. Safety, performance, and dependability have been given top priority in the design of this product making it easy to maintain and operate.

WARRANTY

ONE YEAR FULL WARRANTY ON CRAFTSMAN TOOL

If this Craftsman tool fails due to a defect in material or workmanship within one year from the date of purchase. **Call 1-800-4-MY-HOME®** to arrange for free repair. If this tool is used for commercial or rental purposes, this warranty will apply for only ninety days from the date of purchase. This warranty applies only while this product is in the United States.

This warranty gives you specific legal rights, and you may also have other rights which vary from state to state.

Sears, Roebuck and Co., Dept. 817WA, Hoffman Estates, IL 60179

GENERAL SAFETY RULES

 **WARNING:** Read and understand all instructions. Failure to follow all instructions listed below, may result in electric shock, fire and/or serious personal injury.

READ ALL INSTRUCTIONS

- **KNOW YOUR POWER TOOL.** Read the operator's manual carefully. Learn the saw's applications and limitations as well as the specific potential hazards related to this tool.
- **GUARD AGAINST ELECTRICAL SHOCK BY PREVENTING BODY CONTACT WITH GROUNDED SURFACES.** For example, pipes, radiators, ranges, refrigerator enclosures.
- **KEEP GUARDS IN PLACE** and in good working order.
- **REMOVE ADJUSTING KEYS AND WRENCHES.** Form habit of checking to see that keys and adjusting wrenches are removed from tool before turning it on.
- **KEEP WORK AREA CLEAN.** Cluttered areas and benches invite accidents. **DO NOT** leave tools or pieces of wood on the saw while it is in operation.
- **DO NOT USE IN DANGEROUS ENVIRONMENTS.** Do not use power tools in damp or wet locations or expose to rain. Keep the work area well lit.
- **KEEP CHILDREN AND VISITORS AWAY.** All visitors should wear safety glasses and be kept a safe distance from work area. Do not let visitors contact tool or extension cord while operating.
- **MAKE WORKSHOP CHILDPROOF** with padlocks and master switches, or by removing starter keys.
- **DON'T FORCE TOOL.** It will do the job better and safer at the feed rate for which it was designed.
- **USE RIGHT TOOL.** Don't force the tool or attachment to do a job it was not designed for. Don't use it for a purpose not intended.
- **USE THE PROPER EXTENSION CORD.** Make sure your extension cord is in good condition. Use only a cord heavy enough to carry the current your product will draw. An undersized cord will cause a drop in line voltage resulting in loss of power and overheating. A wire gauge size (A.W.G.) of at least **14** is recommended for an extension cord 25 feet or less in length. If in doubt, use the next heavier gauge. The smaller the gauge number, the heavier the cord.
- **DRESS PROPERLY.** Do not wear loose clothing, gloves, neckties, or jewelry. They can get caught and draw you into moving parts. Rubber gloves and nonskid footwear are recommended when working outdoors. Also wear protective hair covering to contain long hair.
- **ALWAYS WEAR SAFETY GLASSES WITH SIDE SHIELDS.** Everyday eyeglasses have only impact-resistant lenses, they are **NOT** safety glasses.
- **SECURE WORK.** Use clamps or a vise to hold work when practical. It's safer than using your hand and frees both hands to operate tool.
- **DON'T OVERREACH.** Keep proper footing and balance at all times.
- **MAINTAIN TOOLS WITH CARE.** Keep tools sharp and clean for better and safer performance. Follow instructions for lubricating and changing accessories.
- **DISCONNECT TOOLS.** When not in use, before servicing, or when changing attachments, blades, bits, cutters, etc., all tools should be disconnected.
- **AVOID ACCIDENTAL STARTING.** Be sure switch is off when plugging in any tool.
- **USE RECOMMENDED ACCESSORIES.** Consult the operator's manual for recommended accessories. The use of improper accessories may risk injury.
- **NEVER STAND ON TOOL.** Serious injury could occur if the tool is tipped or if the cutting tool is unintentionally contacted.
- **CHECK DAMAGED PARTS.** Before further use of the tool, a guard or other part that is damaged should be carefully checked to determine that it will operate properly and perform its intended function. Check for alignment of moving parts, binding of moving parts, breakage of parts, mounting and any other conditions that may affect its operation. A guard or other part that is damaged must be properly repaired or replaced by an authorized service center to avoid risk of personal injury.
- **USE THE RIGHT DIRECTION OF FEED.** Feed work into a blade or cutter against the direction of rotation of blade or cutter only.
- **NEVER LEAVE TOOL RUNNING UNATTENDED. TURN THE POWER OFF.** Don't leave tool until it comes to a complete stop.
- **PROTECT YOUR LUNGS.** Wear a face or dust mask if the cutting operation is dusty.
- **PROTECT YOUR HEARING.** Wear hearing protection during extended periods of operation.
- **DO NOT ABUSE CORD.** Never yank cord to disconnect from receptacle. Keep cord away from heat, oil, and sharp edges.
- **WHEN OPERATING A POWER TOOL OUTSIDE, USE AN OUTDOOR EXTENSION CORD MARKED "W-A" OR "W".** These cords are rated for outdoor use and reduce the risk of electric shock.
- **KEEP BLADES CLEAN, SHARP, AND WITH SUFFICIENT SET.** Sharp blades minimize stalling and kickback.

GENERAL SAFETY RULES

- **KEEP HANDS AWAY FROM CUTTING AREA.** Keep hands away from blades. Do not reach underneath work or around or over the blade while blade is rotating. Do not attempt to remove cut material when blade is moving.
- **BLADE COASTS AFTER BEING TURNED OFF.**
- **NEVER USE IN AN EXPLOSIVE ATMOSPHERE.** Normal sparking of the motor could ignite fumes.
- **INSPECT TOOL CORDS PERIODICALLY.** If damaged, have repaired by a qualified service technician at an authorized service facility. The conductor with insulation having an outer surface that is green with or without yellow stripes is the equipment-grounding conductor. If repair or replacement of the electric cord or plug is necessary, do not connect the equipment-grounding conductor to a live terminal. Repair or replace a damaged or worn cord immediately. Stay constantly aware of cord location and keep it well away from the rotating blade.
- **INSPECT EXTENSION CORDS PERIODICALLY** and replace if damaged.
- **GROUND ALL TOOLS.** If tool is equipped with three-prong plug, it should be plugged into a three-hole electrical receptacle.
- **CHECK WITH A QUALIFIED ELECTRICIAN** or service personnel if the grounding instructions are not completely understood or if in doubt as to whether the tool is properly grounded.
- **USE ONLY CORRECT ELECTRICAL DEVICES:** 3-wire extension cords that have 3-prong grounding plugs and 3-pole receptacles that accept the tool's plug.
- **DO NOT MODIFY** the plug provided. If it will not fit the outlet, have the proper outlet installed by a qualified electrician.
- **KEEP TOOL DRY, CLEAN, AND FREE FROM OIL AND GREASE.** Always use a clean cloth when cleaning. Never use brake fluids, gasoline, petroleum-based products, or any solvents to clean tool.
- **STAY ALERT AND EXERCISE CONTROL.** Watch what you are doing and use common sense. Do not operate tool when you are tired. Do not rush.
- **DO NOT USE TOOL IF SWITCH DOES NOT TURN IT ON AND OFF.** Have defective switches replaced by an authorized service center.
- **USE ONLY CORRECT BLADES.** Do not use blades with incorrect size holes. Never use blade washers or blade bolts that are defective or incorrect. The maximum blade capacity of your saw is 10 in. (254 mm).
- **BEFORE MAKING A CUT, BE SURE ALL ADJUSTMENTS ARE SECURE.**
- **BE SURE BLADE PATH IS FREE OF NAILS.** Inspect for and remove all nails from lumber before cutting.
- **NEVER TOUCH BLADE** or other moving parts during use.
- **NEVER START A TOOL WHEN ANY ROTATING COMPONENT IS IN CONTACT WITH THE WORKPIECE.**
- **DO NOT OPERATE A TOOL WHILE UNDER THE INFLUENCE OF DRUGS, ALCOHOL, OR ANY MEDICATION.**
- **WHEN SERVICING** use only identical replacement parts. Use of any other parts may create a hazard or cause product damage.
- **USE ONLY RECOMMENDED ACCESSORIES** listed in this manual or addendums. Use of accessories that are not listed may cause the risk of personal injury. Instructions for safe use of accessories are included with the accessory.
- **DOUBLE CHECK ALL SETUPS.** Make sure blade is tight and not making contact with saw or workpiece before connecting to power supply.

SPECIFIC SAFETY RULES

- **FIRMLY BOLT THE SAW TO A WORK BENCH OR LEG STAND** at approximately hip height.
- **NEVER OPERATE THE SAW ON THE FLOOR.**
- **GUARD AGAINST KICKBACK.** Kickback occurs when the blade stalls rapidly and workpiece is driven back towards the operator. It can pull your hand into the blade resulting in serious personal injury. Stay out of blade path and turn switch off immediately if blade binds or stalls.
- **USE RIP FENCE.** Always use a fence or straight edge guide when ripping.
- **SUPPORT LARGE PANELS.** To minimize risk of blade pinching and kickback, always support large panels.
- **REMOVE ALL FENCES AND AUXILIARY TABLES** before transporting saw. Failure to do so can result in an accident causing possible serious personal injury.
- **ALWAYS USE BLADE GUARD, SPREADER, AND ANTI-KICKBACK PAWLS** on all "through-sawing" operations. Through-sawing operations are those in which the blade cuts completely through the workpiece as in ripping or cross cutting. Keep the blade guard down, the anti-kickback pawls down, and the spreader in place.

SPECIFIC SAFETY RULES

- **ALWAYS SECURE WORK** firmly against the rip fence or miter gauge. **NEVER** use the rip fence during the same operation as the miter gauge.
- **WHEN MAKING NON-THROUGH RIP CUTS**, always use a push stick, push block, and/or featherboard so your hands do not come within 3 inches of the saw blade.
- **WHEN RIPPING NARROW STOCK**, always use a push stick, push block, or featherboard.
- **NEVER** perform any operation “freehand” which means using only your hands to support or guide the workpiece. Always use either the rip fence or miter gauge to position and guide the work.
- **NEVER** stand or have any part of your body in line with the path of the saw blade.
- **NEVER** reach behind, over, or within three inches of the blade or cutter with either hand for any reason.
- **MOVE THE RIP FENCE** out of the way when cross cutting.
- **DO NOT USE THE MITER GAUGE AND RIP FENCE** during the same operation.
- **NEVER** use rip fence as cutoff gauge when cross cutting.
- **NEVER** attempt to free a stalled saw blade without first turning the saw **OFF** and disconnecting the saw from the power source.
- **PROVIDE ADEQUATE SUPPORT** to the rear and sides of the saw table for wide or long work pieces.
- **AVOID KICKBACKS** (work thrown back toward you) by:
 - a) Keeping blade sharp.
 - b) Keeping rip fence parallel to the saw blade.
 - c) Keeping spreader, anti-kickback pawls, and blade guard in place and operating.
 - d) Not releasing the work before it is pushed all the way past the saw blade using a push stick.
 - e) Not ripping work that is twisted or warped or does not have a straight edge to guide along the fence.
- **IF THE POWER SUPPLY CORD IS DAMAGED**, it must be replaced only by the manufacturer or by an authorized service center to avoid risk.
- **AVOID AWKWARD OPERATIONS AND HAND POSITIONS** where a sudden slip could cause your hand to move into the cutting tool.
- **USE ONLY RECOMMENDED ACCESSORIES** listed in this manual or addendums. Use of accessories that are not listed may cause the risk of personal injury. Instructions for safe use of accessories are included with the accessory.
- **MAKE SURE THE WORK AREA HAS AMPLE LIGHTING** to see the work and that no obstructions will interfere with safe operation **BEFORE** performing any work using the table saw.
- **ALWAYS TURN OFF SAW** before disconnecting it, to avoid accidental starting when reconnecting to power supply.
- **ONLY USE BLADES** within the thickness range stamped on the spreader/riving knife.
- **THIS TOOL** should have the following markings:
 - a) Wear eye protection.
 - b) Use saw blade guard and spreader/riving knife for every operation for which it can be used, including all through sawing.
 - c) Keep hands out of the line of saw blade.
 - d) Use a push stick when required.
 - e) Pay particular attention to instructions on reducing risk of kickback.
 - f) Do not perform any operation freehand.
 - g) Never reach around or over the saw blade.
 - h) Never operate saw on floor or below waist height.
- **NEVER CUT MORE THAN ONE PIECE OF MATERIAL AT A TIME.**
- **SAVE THESE INSTRUCTIONS.** Refer to them frequently and use to instruct other users. If you loan someone this tool, loan them these instructions also.







 **WARNING:** Some dust created by power sanding, sawing, grinding, drilling, and other construction activities contains chemicals known to cause cancer, birth defects or other reproductive harm. Some examples of these chemicals are:

- lead from lead-based paints,
- crystalline silica from bricks and cement and other masonry products, and
- arsenic and chromium from chemically-treated lumber.

Your risk from these exposures varies, depending on how often you do this type of work. To reduce your exposure to these chemicals: work in a well ventilated area, and work with approved safety equipment, such as those dust masks that are specially designed to filter out microscopic particles.



SYMBOLS

Some of the following symbols may be used on this tool. Please study them and learn their meaning. Proper interpretation of these symbols will allow you to operate the tool better and safer.

SYMBOL	NAME	DESIGNATION/EXPLANATION
	Safety Alert	Indicates a potential personal injury hazard.
	Read Operator's Manual	To reduce the risk of injury, user must read and understand operator's manual before using this product.
	Eye Protection	Always wear eye protection marked to comply with ANSI Z87.1.
	No Hands Symbol	Failure to keep your hands away from the blade will result in serious personal injury.
	Wet Conditions Alert	Do not expose to rain or use in damp locations.
V	Volts	Voltage
A	Amperes	Current
Hz	Hertz	Frequency (cycles per second)
W	Watt	Power
min	Minutes	Time
~	Alternating Current	Type of current
—	Direct Current	Type or a characteristic of current
n_0	No Load Speed	Rotational speed, at no load
	Class II Construction	Double-insulated construction
.../min	Per Minute	Revolutions, strokes, surface speed, orbits etc., per minute

SYMBOLS

The following signal words and meanings are intended to explain the levels of risk associated with this product.

SYMBOL	SIGNAL	MEANING
	DANGER:	Indicates an imminently hazardous situation, which, if not avoided, will result in death or serious injury.
	WARNING:	Indicates a potentially hazardous situation, which, if not avoided, could result in death or serious injury.
	CAUTION:	Indicates a potentially hazardous situation, which, if not avoided, may result in minor or moderate injury.
	CAUTION:	(Without Safety Alert Symbol) Indicates a situation that may result in property damage.

SERVICE

Servicing requires extreme care and knowledge and should be performed only by a qualified service technician. For service we suggest you return the product to your nearest **AUTHORIZED SERVICE CENTER** for repair. When servicing, use only identical replacement parts.



WARNING: To avoid serious personal injury, do not attempt to use this product until you read thoroughly and understand completely the operator's manual. Save this operator's manual and review frequently for continuing safe operation and instructing others who may use this product.

WARNING:



The operation of any power tool can result in foreign objects being thrown into your eyes, which can result in severe eye damage. Before beginning power tool operation, always wear safety goggles or safety glasses with side shields and a full face shield when needed. We recommend Wide Vision Safety Mask for use over eyeglasses or standard safety glasses with side shields. Always use eye protection which is marked to comply with ANSI Z87.1.

SAVE THESE INSTRUCTIONS

ELECTRICAL

EXTENSION CORDS

Use only 3-wire extension cords that have 3-prong grounding plugs and 3-pole receptacles that accept the tool's plug. When using a power tool at a considerable distance from the power source, use an extension cord heavy enough to carry the current that the tool will draw. An undersized extension cord will cause a drop in line voltage, resulting in a loss of power and causing the motor to overheat. Use the chart provided below to determine the minimum wire size required in an extension cord. Only round jacketed cords listed by Underwriter's Laboratories (UL) should be used.

**Ampere rating (on tool data plate)

Cord Length	Wire Size (A.W.G.)					
	0-2.0	2.1-3.4	3.5-5.0	5.1-7.0	7.1-12.0	12.1-16.0
25'	16	16	16	16	14	14
50'	16	16	16	14	14	12
100'	16	16	14	12	10	—

**Used on 12 gauge - 20 amp circuit.

NOTE: AWG = American Wire Gauge

When working with the tool outdoors, use an extension cord that is designed for outside use. This is indicated by the letters "WA" on the cord's jacket.

Before using an extension cord, inspect it for loose or exposed wires and cut or worn insulation.

WARNING: Keep the extension cord clear of the working area. Position the cord so that it will not get caught on lumber, tools or other obstructions while you are working with a power tool. Failure to do so can result in serious personal injury.

WARNING: Check extension cords before each use. If damaged replace immediately. Never use tool with a damaged cord since touching the damaged area could cause electrical shock resulting in serious injury.

ELECTRICAL CONNECTION

This tool is powered by a precision built electric motor. It should be connected to a **power supply that is 120 volts, AC only (normal household current), 60 Hz.** Do not operate this tool on direct current (DC). A substantial voltage drop will cause a loss of power and the motor will overheat. If the saw does not operate when plugged into an outlet, double check the power supply.

SPEED AND WIRING

The no-load speed of this tool is approximately 5,000 rpm. This speed is not constant and decreases under a load or with lower voltage. For voltage, the wiring in a shop is as important as the motor's horsepower rating. A line intended only for lights cannot properly carry a power tool motor. Wire that is heavy enough for a short distance will be too light for a greater distance. A line that can support one power tool may not be able to support two or three tools.

GROUNDING INSTRUCTIONS

This product must be grounded. In the event of a malfunction or breakdown, grounding provides a path of least resistance for electric current to reduce the risk of electric shock. This tool is equipped with an electric cord having an equipment-grounding conductor and a grounding plug. The plug must be plugged into a matching outlet that is properly installed and grounded in accordance with all local codes and ordinances.

Do not modify the plug provided. If it will not fit the outlet, have the proper outlet installed by a qualified electrician.

WARNING: Improper installation of the grounding plug can result in a risk of electric shock. When repair or replacement of the cord is required, do not connect the grounding wire to either flat blade terminal. The wire with insulation having an outer surface that is green with or without yellow stripes is the grounding wire.

Check with a qualified electrician or service personnel if the grounding instructions are not completely understood, or if in doubt as to whether the tool is properly grounded. Repair or replace a damaged or worn cord immediately. This product is for use on a nominal 120 volt circuit and has a grounding plug similar to the plug illustrated in figure 1. Only connect the product to an outlet having the same configuration as the plug. Do not use an adapter with this product.

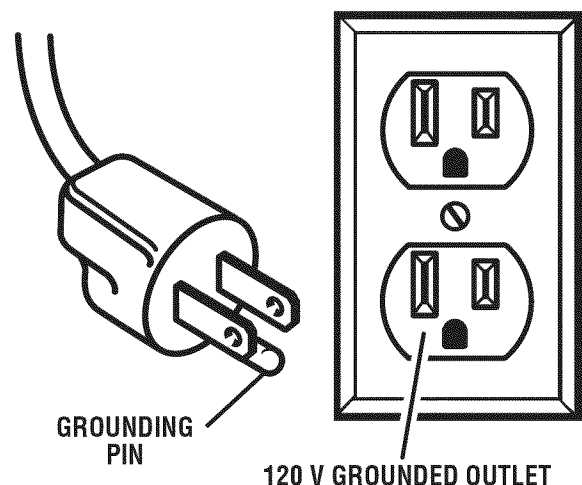

Fig. 1

GLOSSARY OF TERMS

Anti-Kickback Pawls (flooring, radial arm, and table saws)

A device which, when properly installed and maintained, is designed to stop the workpiece from being kicked back toward the front of the saw during a ripping operation.

Arbor

The shaft on which a blade or cutting tool is mounted.

Bevel Cut

A cutting operation made with the blade at any angle other than 90° to the table surface.

Compound Cut

A cross cut made with both a miter and a bevel angle.

Cross Cut

A cutting or shaping operation made across the grain or the width of the workpiece.

Cutterhead (planers and jointer planers)

A rotating cutterhead with adjustable blades or knives. The blades or knives remove material from the workpiece.

Dado Cut

A non-through cut which produces a square-sided notch or trough in the workpiece (requires a special blade).

Featherboard

A device used to help control the workpiece by holding it securely against the table or fence during any ripping operation.

FPM or SPM

Feet per minute (or strokes per minute), used in reference to blade movement.

Freehand

Performing a cut without the workpiece being guided by a fence, miter gauge, or other aids.

Gum

A sticky, sap-based residue from wood products.

Heel

Alignment of the blade to the fence.

Kerf

The material removed by the blade in a through cut or the slot produced by the blade in a non-through or partial cut.

Kickback

A hazard that can occur when the blade binds or stalls, throwing the workpiece back toward operator.

Miter Cut

A cutting operation made with the workpiece at any angle to the blade other than 90°.

Non-Through Cuts

Any cutting operation where the blade does not extend completely through the thickness of the workpiece.

Pilot Hole (drill presses)

A small hole drilled in a workpiece that serves as a guide for drilling large holes accurately.

Push Blocks (jointer planers)

Device used to feed the workpiece over the jointer planer cutterhead during any operation. This aid helps keep the operator's hands well away from the cutterhead.

Push Blocks (flooring and table saws)

Device used to hold the workpiece during cutting operations. This aid helps keep the operator's hands well away from the blade.

Push Sticks (flooring and table saws)

Device used to push the workpiece during cutting operations. A push stick should be used for narrow ripping operations. The aid helps keep the operator's hands well away from the blade.

Resaw

A cutting operation to reduce the thickness of the workpiece to make thinner pieces.

Resin

A sticky, sap-based substance that has hardened.

Revolutions Per Minute (RPM)

The number of turns completed by a spinning object in one minute.

Ripping or Rip Cut

A cutting operation along the length of the workpiece.

Riving Knife/Spreader/Splitter (flooring and table saws)

A metal piece, slightly thinner than the blade, which helps keep the kerf open and also helps to prevent kickback.

Saw Blade Path

The area over, under, behind, or in front of the blade. As it applies to the workpiece, that area which will be or has been cut by the blade.

Set

The distance that the tip of the saw blade tooth is bent (or set) outward from the face of the blade.

Snipe (planers)

Depression made at either end of a workpiece by cutter blades when the workpiece is not properly supported.

Through Sawing

Any cutting operation where the blade extends completely through the thickness of the workpiece.

Throw-Back

The throwing back of a workpiece usually caused by the workpiece being dropped into the blade or being placed inadvertently in contact with the blade.

Workpiece or Material

The item on which the operation is being done.

Worktable

Surface where the workpiece rests while performing a cutting, drilling, planing, or sanding operation.

FEATURES

PRODUCT SPECIFICATIONS

Blade Arbor	5/8 in.	Input	15 Amps
Blade Diameter	10 in.	No Load Speed	5,000 r/min. (RPM)
Blade Tilt	0° - 45°	Cutting Depth at 0°	3 in.
Rating	120 V, AC only, 60 Hz	Cutting Depth at 45°	2-5/8 in.

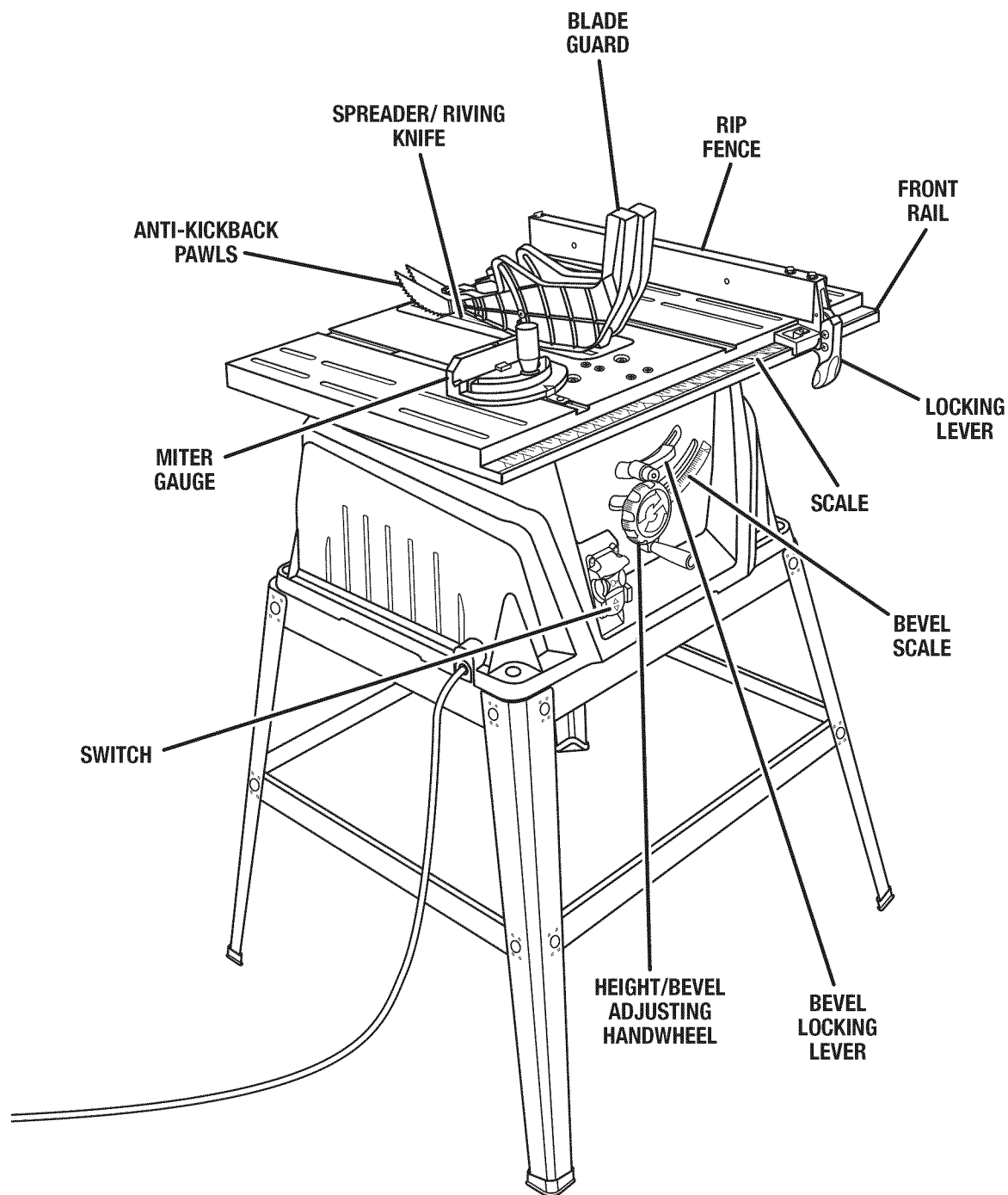

Fig. 2

FEATURES

KNOW YOUR TABLE SAW

See Figure 2.

The safe use of this product requires an understanding of the information on the tool and in this operator's manual as well as a knowledge of the project you are attempting. Before use of this product, familiarize yourself with all operating features and safety rules.

ANTI-KICKBACK PAWLS - Kickback is a hazard in which the workpiece is thrown back toward the operator. The teeth on the removable anti-kickback pawls point away from the workpiece. If the workpiece should be pulled back toward the operator, the teeth dig into the wood to help prevent or reduce the possibility of kickback.

BEVEL SCALE - The easy-to-read scale on the front of the cabinet shows the exact blade angle.

BLADE - This saw is provided with a 24-tooth, 10 in. carbide blade. The blade is raised and lowered with the height/bevel adjusting handwheel. Bevel angles are locked with the bevel locking lever.

 **WARNING:** Do not use blades rated less than the speed of this tool. Failure to heed this warning could result in personal injury.

BLADE GUARD - Always keep the removable blade guard down over the saw blade for through-sawing cuts.

BEVEL LOCKING LEVER - This lever, placed just under the saw table surface on the front of the cabinet, locks the angle setting of the blade.

HEIGHT/BEVEL ADJUSTING HANDWHEEL - Located on the front of the cabinet, use this handwheel to lower and raise the blade for height adjustments or blade replacement. This handwheel also makes the adjustment for bevel angles easy.

MITER GAUGE - The miter gauge aligns the wood for a cross cut. The easy-to-read indicator shows the exact angle for a miter cut.

MITER GAUGE GROOVES - The miter gauge rides in the grooves on the saw table.

RIP FENCE - A sturdy metal fence guides the workpiece and is secured with the locking lever.

SCALE - Located on the front rail, the easy-to-read scale provides precise measurements for rip cuts.

SPREADER / RIVING KNIFE - A removable metal piece of the blade guard assembly, slightly thinner than the saw blade, which helps keep the kerf open and prevent kickback. When in the through sawing, or "up" position, it is higher than the saw blade and becomes a spreader. When in the non-through sawing, or "down" position, it is below the saw blade teeth and becomes a riving knife.

SWITCH ASSEMBLY - This saw has an easy access power switch located below the front rail. To lock the switch in the **OFF** position, remove the switch key from the switch. Place the key in a location that is inaccessible to children and others not qualified to use the tool.

FEATURES

OPERATING COMPONENTS

The upper portion of the blade projects up through the table and is surrounded by an insert called the throat plate. The height of the blade is set with a handwheel on the front of the cabinet. To accommodate wide panels, the saw table has rails on each side. Detailed instructions are provided in the *Operation* section of this manual for the basic cuts: cross cuts, miter cuts, bevel cuts, and compound cuts.

The rip fence is used to position work for lengthwise cuts. A scale on the front rail shows the distance between the rip fence and the blade.

It is very important to use the blade guard assembly for all through-sawing operations. The blade guard assembly includes: riving knife/spreader/splitter, anti-kickback pawls, and plastic blade guard.

SWITCH ASSEMBLY

See Figure 3.

This saw is equipped with a switch assembly that has a built-in locking feature. This feature is intended to prevent unauthorized and possible hazardous use by children and others.

TO TURN YOUR SAW ON:

- With the switch key inserted into the switch, lift the switch to turn on (I).

TO TURN YOUR SAW OFF:

- Press the switch down to turn off (O).

TO LOCK YOUR SAW:

- Press the switch down.
- Remove the switch key from the switch and store in a safe, secure location.

⚠ WARNING: ALWAYS remove the switch key when the tool is not in use and keep it in a safe place. In the event of a power failure, turn the switch off (O) and remove the key. This action will prevent the tool from accidentally starting when power returns.

⚠ WARNING: ALWAYS make sure your workpiece is not in contact with the blade before operating the switch to start the tool. Failure to heed this warning may cause the workpiece to be kicked back toward the operator and result in serious personal injury.

⚠ WARNING: To reduce the risk of accidental starting, Always make sure the switch is in the off (O) position before plugging tool into the power source.

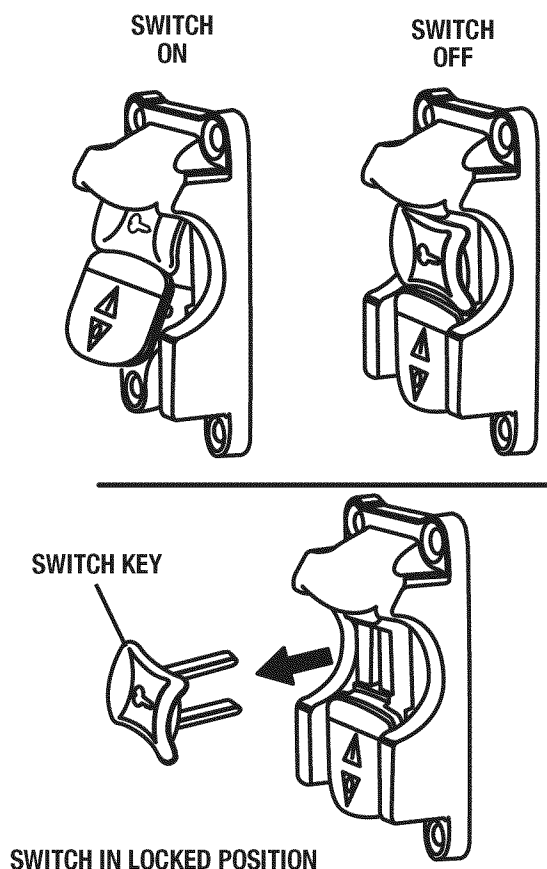

Fig. 3

FEATURES

BLADES

For maximum performance, it is recommended that you use the 24-tooth, 10 in. carbide-tipped combination blade provided with your saw. Additional blade styles of the same high quality are available for specific operations such as ripping. Your local dealer can provide you with complete information.

Kerf width must be within the limits stamped on the spreader/riving knife.



WARNING: Do not use blades rated less than the speed of this tool. Failure to heed this warning could result in personal injury.

TOOLS NEEDED

The following tools (not included or drawn to scale) are needed for assembly and making adjustments:

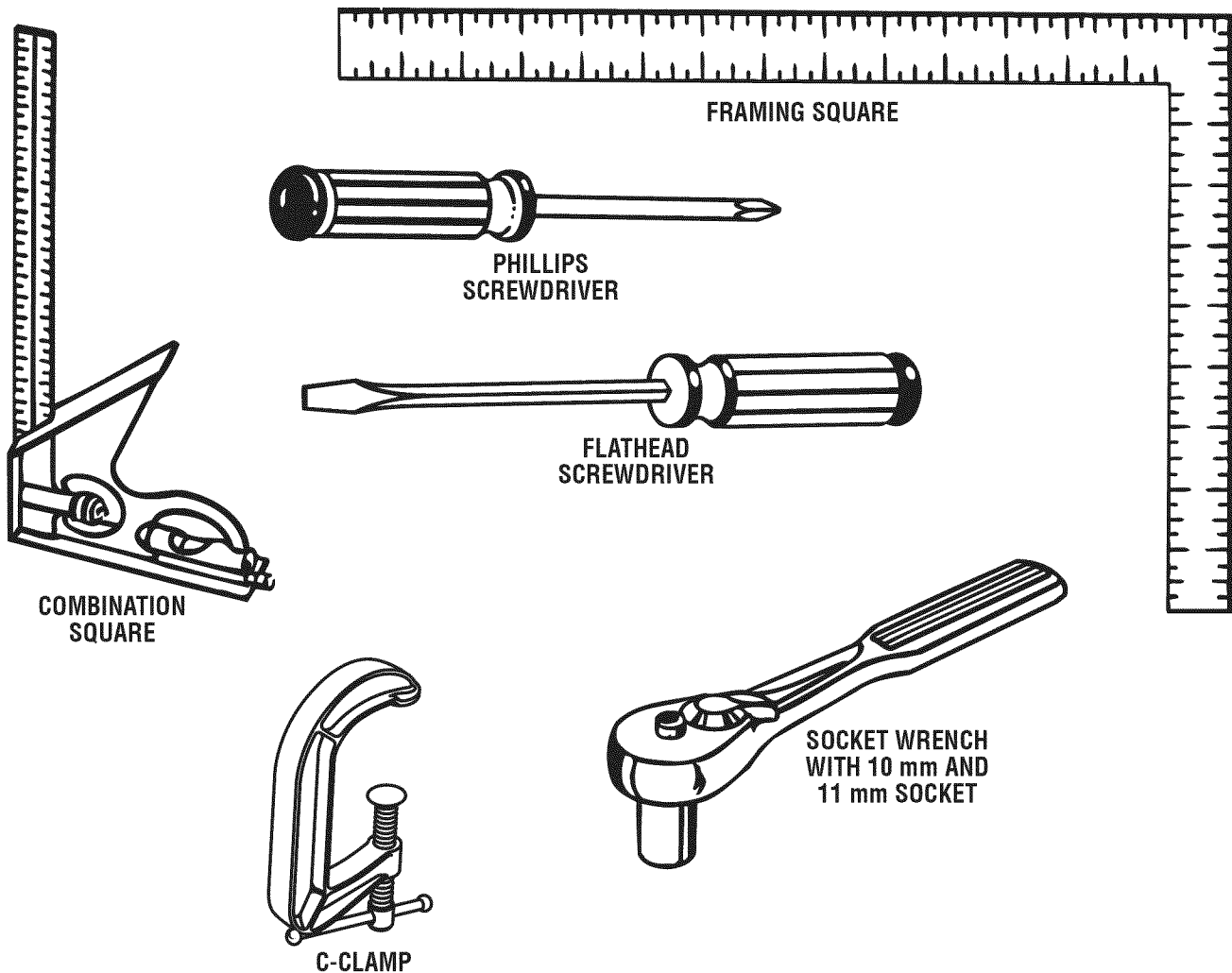

Fig. 4

LOOSE PARTS

The following items are included with the table saw:

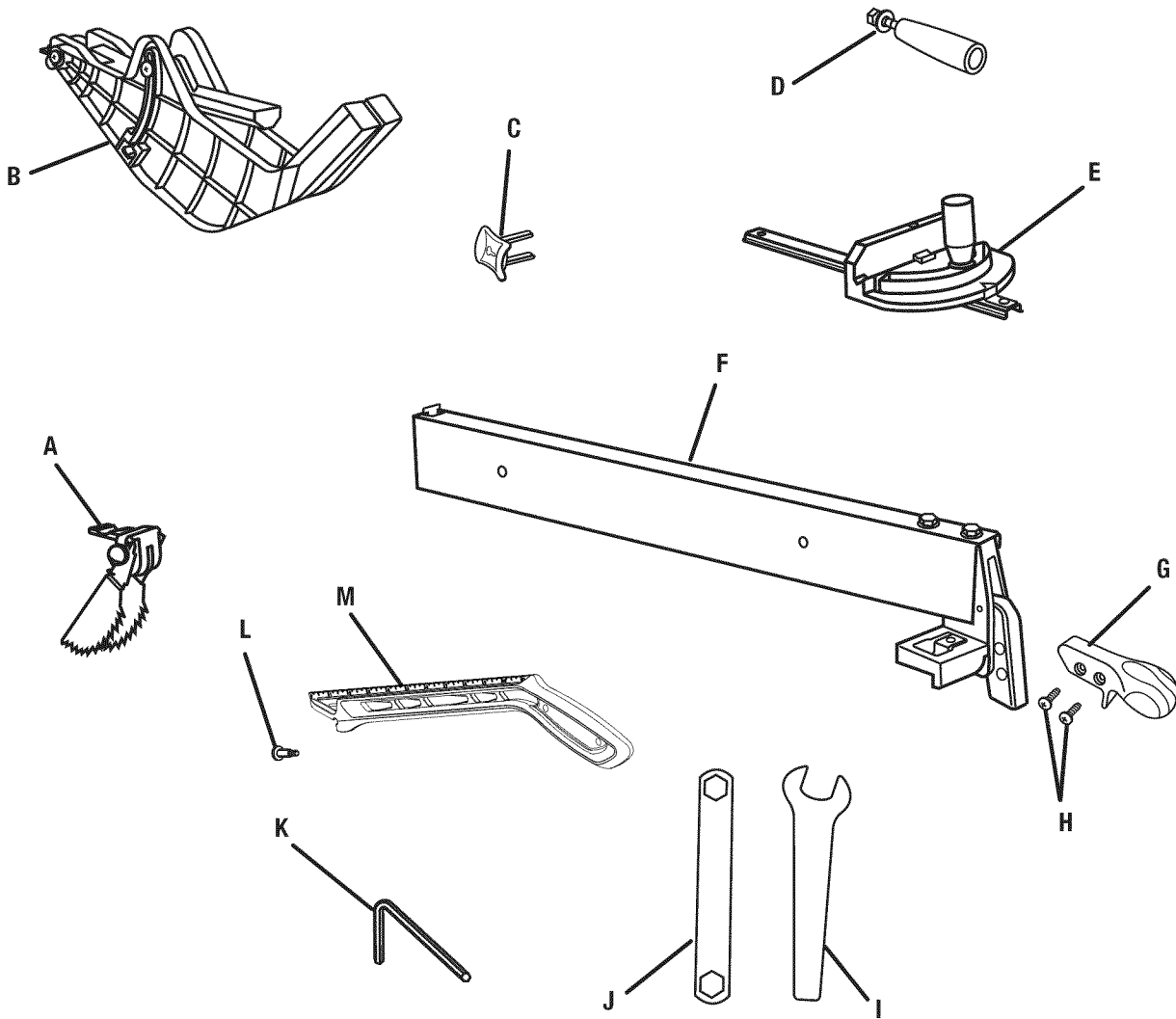

Fig. 5

A. Anti-Kickback Pawls.....	1	H. Screw.....	2
B. Blade Guard.....	1	I. Open End Wrench.....	1
C. Switch Key.....	1	J. Closed End Wrench.....	1
D. Handle.....	1	K. Hex Key (5 mm).....	1
E. Miter Gauge.....	1	L. Push Stick Storage Screw.....	2
F. Rip Fence.....	1	M. Push Stick.....	1
G. Locking Lever.....	1		

LOOSE PARTS

The following items are included with the table saw leg stand:

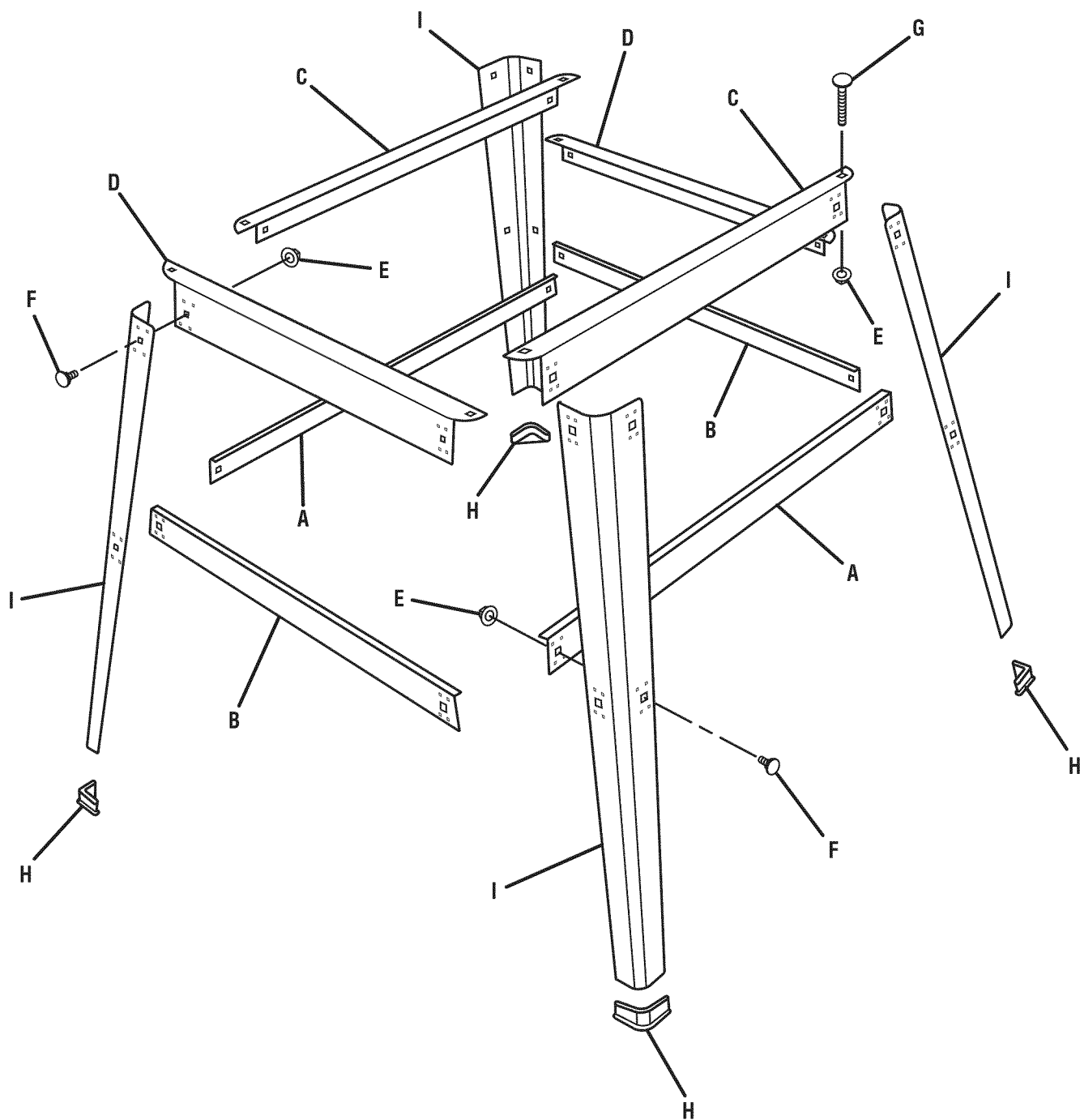

Fig. 6

A. Lower Brace.....	2	F. Carriage Bolt (1/4 - 20 x 1/2 in.).....	16
B. Lower Side Brace.....	2	G. Carriage Bolt (1/4 - 20 x 1-3/8 in.).....	4
C. Upper Brace.....	2	H. Foot.....	4
D. Upper Side Brace.....	2	I. Leg.....	4
E. Hex Nut.....	20		

ASSEMBLY

UNPACKING

This product requires assembly.

- Carefully lift saw from the carton and place it on a level work surface.

NOTE: This tool is heavy. To avoid back injury, keep your knees bent and lift with your legs, not your back, and get help when needed.

WARNING: Do not use this product if any parts on the Loose Parts List are already assembled to your product when you unpack it. Parts on this list are not assembled to the product by the manufacturer and require customer installation. Use of a product that may have been improperly assembled could result in serious personal injury.

- Inspect the tool carefully to make sure no breakage or damage occurred during shipping.
- Do not discard the packing material until you have carefully inspected the tool, identified all loose parts, and satisfactorily operated the tool.

NOTE: Remove the foam block from between the saw's housing and the motor by first beveling the blade (see page 27).

- The saw is factory set for accurate cutting. After assembling it, check for accuracy. If shipping has influenced the settings, refer to specific procedures explained in this manual.
- If any parts are damaged or missing, please call 1-800-932-3188 for assistance.

WARNING: If any parts are damaged or missing, do not operate this tool until the parts are replaced. Use of this product with damaged or missing parts could result in serious personal injury.

WARNING: Do not attempt to modify this tool or create accessories not recommended for use with this tool. Any such alteration or modification is misuse and could result in a hazardous condition leading to possible serious personal injury.

WARNING: Do not connect to power supply until assembly is complete. Failure to comply could result in accidental starting and possible serious personal injury.

WARNING: Do not lift the saw without help. Hold it close to your body. Keep your knees bent and lift with your legs, not your back. Ignoring these precautions can result in back injury.

WARNING: Never stand directly in line with the blade or allow hands to come closer than 3 in. to the blade. Do not reach over or across the blade. Failure to heed this warning can result in serious personal injury.

WARNING: To avoid serious personal injury, always make sure the table saw is securely mounted to a workbench or an approved leg stand. NEVER operate the saw on the floor.

MOUNTING HOLES

The table saw must be mounted to a firm supporting surface such as a workbench or leg stand. Four bolt holes have been provided in the saw's base for this purpose. Each of the four mounting holes should be bolted securely using 1/4 in. machine bolts, lock washers, and hex nuts (not included). Bolts should be of sufficient length to accommodate the saw base, lock washers, hex nuts, and the thickness of the workbench. Tighten all four bolts securely.

Carefully check the workbench after mounting to make sure that no movement can occur during use. If any tipping, sliding, or walking is noted, secure the workbench to the floor before operating.

ASSEMBLY

TO ASSEMBLE THE LEG STAND

See Figure 7.

Assembly is best done in the area where the saw will be used. If you are unsure about the description of any part, refer to the drawing. If any parts are missing, delay assembling until you have obtained the missing part(s).

- Take the following from a small hardware pack:
 - 16 carriage bolts (1/4 - 20 x 1/2 in.)
 - 16 hex nuts (1/4 - 20)
- Take 4 legs and 8 braces from loose parts.
- Place an upper brace inside two of the legs, with the legs wide end up. (Upper braces have two large holes in each end.) Make sure the dimples on the leg align with the small holes on the brace.
- Align the large holes on the brace and the legs. Insert the bolts. Add hex nuts and hand tighten. Repeat for the other upper brace. These are the front and back sets.
- For the side sets, install an upper side brace on two legs. Add hardware and finger tighten.
- Use the same steps to install the lower braces. Tighten all hex nuts securely with the socket wrench.
- Install a foot to the bottom of each leg.
- Move the leg set to desired location.

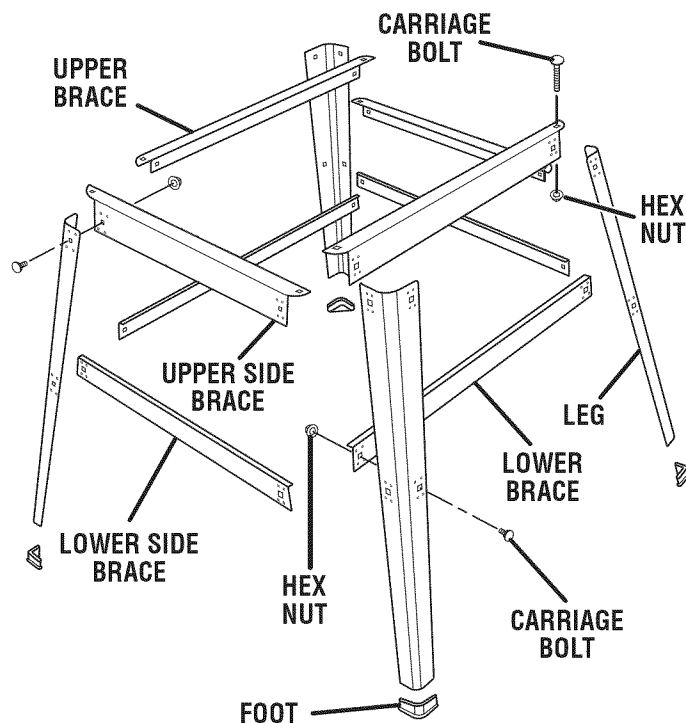

Fig. 7

MOUNTING THE TABLE SAW BASE ON THE LEG STAND

See Figure 8.

- Take the following from a small hardware pack:
 - 4 carriage bolts (1/4-20 x 1-3/8 in.)
 - 4 hex nuts (1/4-20)

NOTE: This hardware was in the pack with hardware for assembling the leg stand and leveling feet.

- Place the table saw base on the leg stand. Align the holes in the table with the holes in the end braces.
- Place a bolt in each hole. Secure with a hex nut. Hand tighten.
- Repeat for three remaining holes. Tighten all hardware securely with the socket wrench.

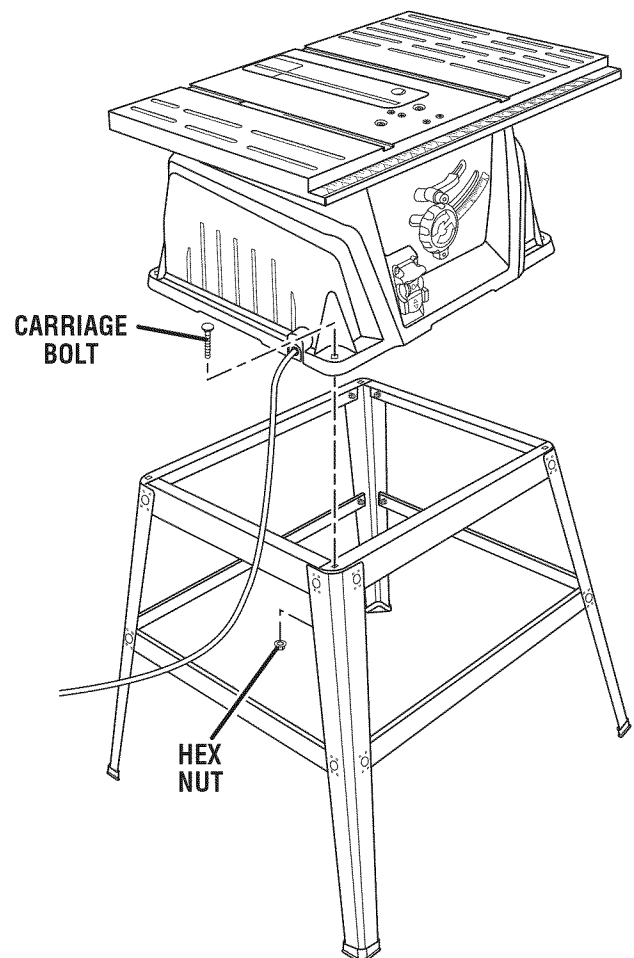

Fig. 8

ASSEMBLY

TO INSTALL THE HANDLE

See Figure 9.

- Hold the nylon nut securely and turn the screw counter-clockwise to remove the nut completely.
NOTE: Do not remove the screw from the handle.
- Place the nylon nut into the recessed hole on the back of the height/bevel adjusting handwheel and hold in place.
- Slide the handle, screw, and washer into the hole on the height/bevel adjusting handwheel.
- Using a flathead screwdriver, turn the screw clockwise and tighten in place.

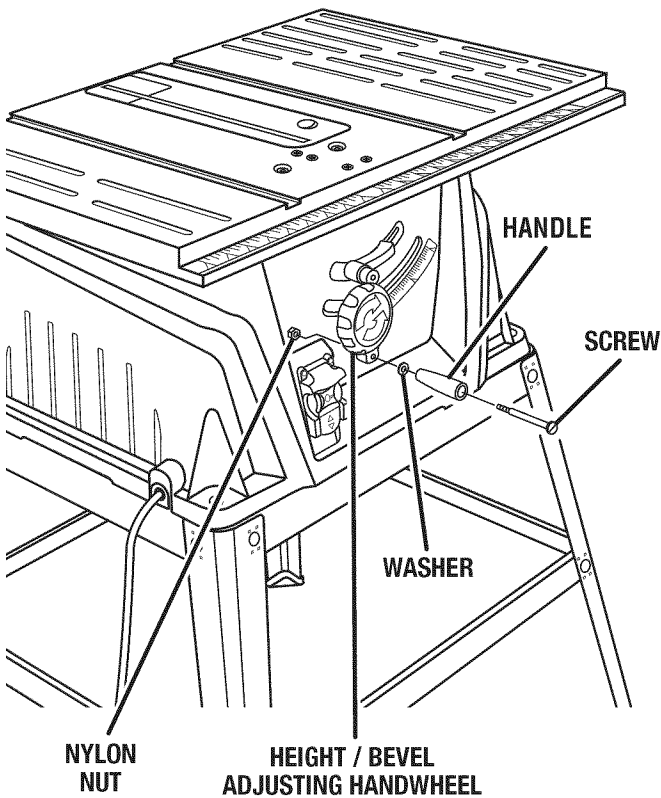

Fig. 9

TO INSTALL THE LOCKING LEVER

See Figure 10.

- Slide the locking lever over the exposed end of the rip fence making certain the handle is inserted as far as possible.
- Align the holes in the rip fence and the holes in the lever. Secure using the screws.

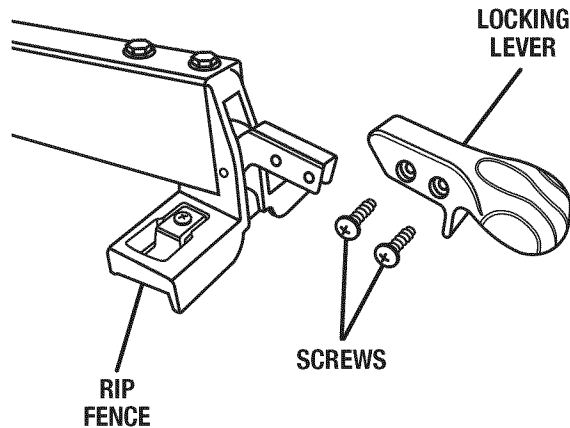

Fig. 10

TO REMOVE/REPLACE THE THROAT PLATE

See Figure 11.

- Lower the blade by turning the height/bevel adjusting handwheel counterclockwise.
- To remove the throat plate, place your index finger in the hole and lift the front end pulling the throat plate out toward the front of the saw.
- To reinstall the throat plate, slip the tab into the slot at the back of the saw and push down to secure in place.

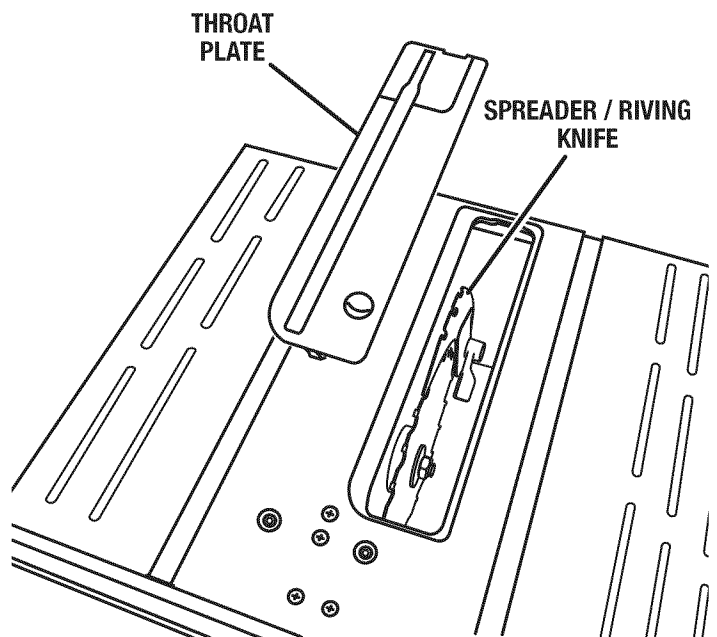

Fig. 11

ASSEMBLY

TO CHANGE BETWEEN A SPREADER AND A RIVING KNIFE

See Figure 12.

This saw is shipped with the spreader/riving knife placed in the non-through cutting or “down” position (riving knife position).

NOTE: The spreader/riving knife must be placed in the through cutting, or “up” position (spreader position), for all other cutting operations.

- Unplug the saw.

To place in spreader position (or “up” position for all through cutting):

- Remove the throat plate.
- Raise the saw blade by turning the height/bevel adjusting handwheel clockwise.
- Unlock the release lever by pulling it up.
- Grasp the spreader and pull it towards the right side of the saw to release the spreader from the spring-loaded riving clamp.
- Pull the spreader up until the internal pins are engaged and the spreader is above the saw blade.
- Lock the release lever by pushing the lever down.
- Reinstall the throat plate.

To place in riving knife position (or “down” position for all non-through cutting):

- Remove the throat plate.
- Raise the saw blade by turning the height/bevel adjusting handwheel clockwise.
- Unlock the release lever by pulling it up.
- Push the riving knife down until it is below the saw blade.
- Lock the release lever by pushing the lever down.
- Reinstall the throat plate.

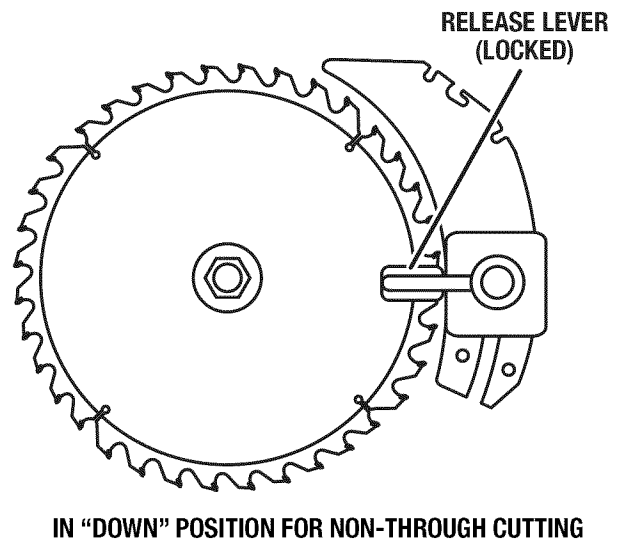
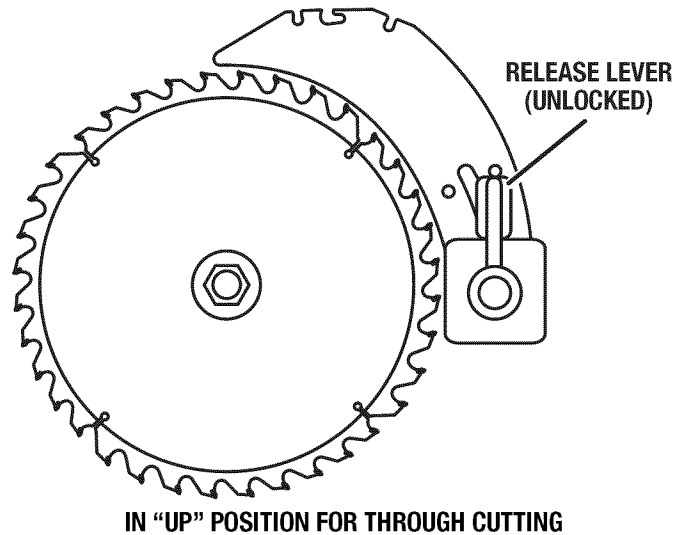

Fig. 12

ASSEMBLY

TO CHECK SAW BLADE INSTALLATION

See Figure 13.

CAUTION: To work properly, the saw blade teeth must point down toward the front of the saw. Failure to do so could cause damage to the saw blade, the saw, or the workpiece.

- Unplug the saw.
- Lower the saw blade and remove the throat plate.
- Make sure the bevel locking lever is securely pushed to the right. Raise the saw blade to its full height by turning the height/bevel adjusting handwheel clockwise.
- Place spreader/riving knife in “up” position.

To loosen the blade:

- Using the open-end wrench, place the open end onto the flats on the arbor shaft.
- Insert the closed-end wrench over the blade nut. Holding both wrenches firmly, pull the closed end wrench forward to the front of the machine.

To tighten the blade:

- Using the open-end wrench, place the open end onto the flats on the arbor shaft.
- Insert the closed-end wrench over the blade nut. Holding both wrenches firmly, push the closed-end wrench to the back of the machine. Make sure the blade nut is securely tightened. Do not over-tighten.
- Reinstall the throat plate.
- Check all clearances for free blade rotation.

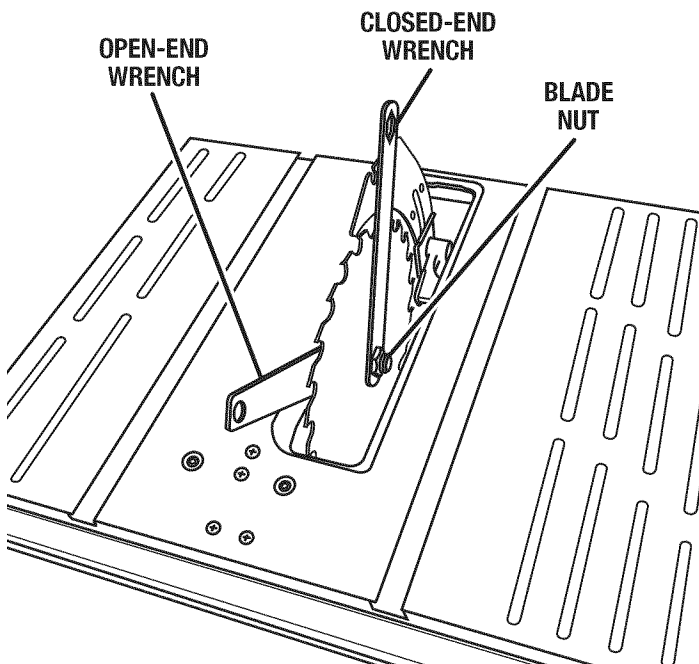

Fig. 13

TO INSTALL THE BLADE GUARD AND ANTI-KICKBACK PAWLS

See Figures 14 - 16.

WARNING: Replace dull or damaged anti-kickback pawls. Dull or damaged pawls may not stop a kick-back increasing the risk of serious personal injury.

NOTE: Anti-kickback pawls should only be installed for through cuts.

- Unplug the saw.
- Raise the saw blade by turning the height/bevel adjusting handwheel clockwise.
- Place spreader/riving knife in “up” position.

To install blade guard:

- Lift the guard lever up to unlock.
- With the front of the blade guard raised, lower the back of the guard into the middle hole of the spreader/riving knife. Push the front of the guard down until it is **parallel to the table** (see figure 15). If the blade guard is not parallel to the table, the riving knife is not in the spreader (or “up”) position.
- Lock the guard in place by pushing the guard lever down.

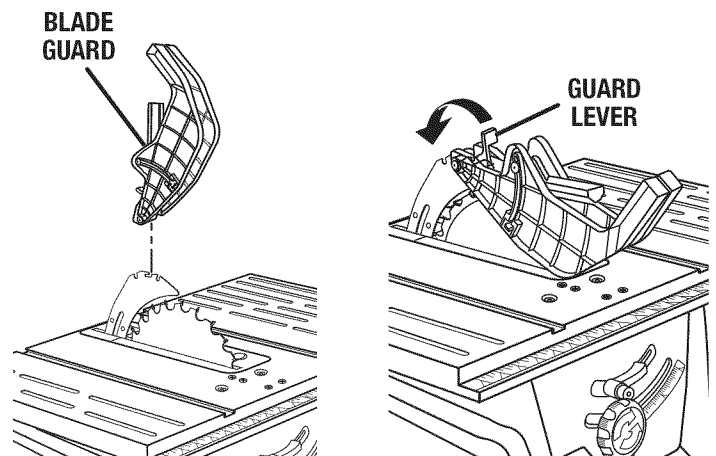

Fig. 14

ASSEMBLY

To install anti-kickback pawls:

- Press and hold the button on the right side of the anti-kickback pawls.
- Align the slot in the pawls over the rear hole in the spreader/riving knife.
- Push the pawl handle down snapping them into place and release the button.

NOTE: Pull on the pawl handle to make sure pawls are securely locked.

NOTE: Blade alignment with the spreader can be adjusted for different blade widths. Refer to: **To Check and Align the Spreader/Riving Knife and Saw Blade.** Check the blade guard assembly for clearances and free movement.

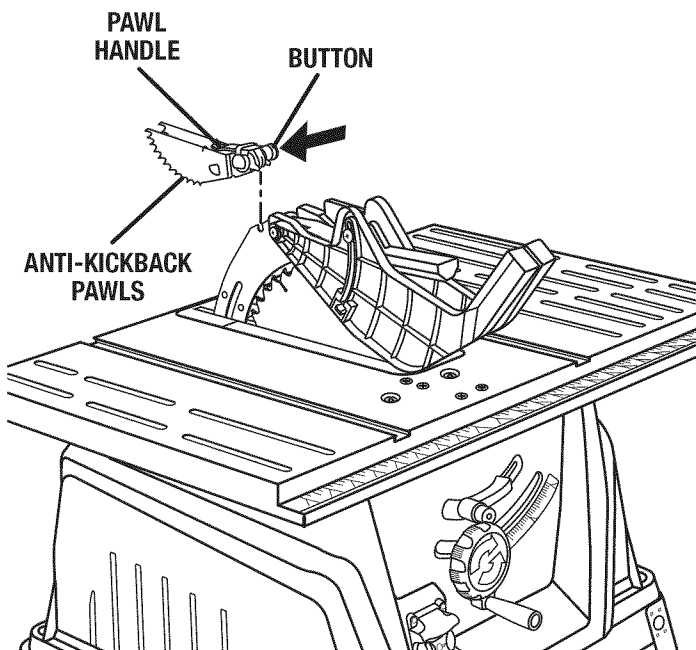

Fig. 15

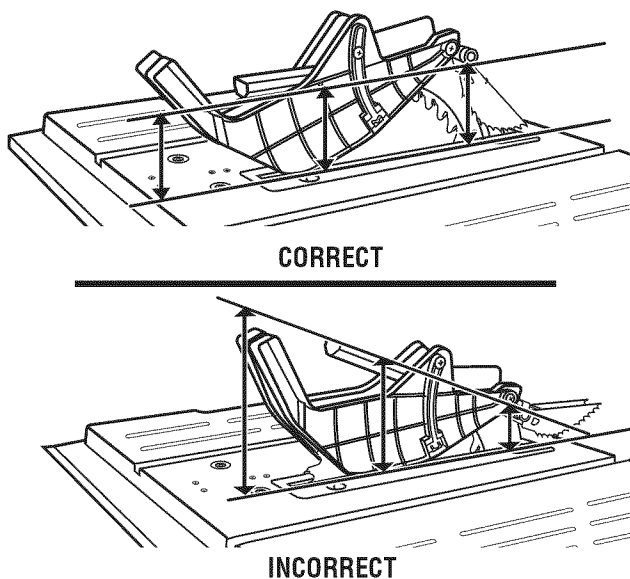

Fig. 16

TO CHECK AND ALIGN THE SPREADER/RIVING KNIFE AND SAW BLADE

See Figures 17 - 18.

To check alignment of the spreader/riving knife:

- Unplug the saw.
- Raise the saw blade by turning the height/bevel adjusting handwheel clockwise.
- Remove the anti-kickback pawls and blade guard assembly. Place a framing square or straight edge against both the saw blade and the spreader.

NOTE: Place framing square between carbide teeth and measure from blade. This step will insure framing square is square against blade from the front to back of blade.

- The saw blade and spreader/riving knife are aligned when the framing square contacts both the blade and spreader/riving knife evenly with no gaps.

If the spreader/riving knife is out of alignment with the saw blade, adjustment is needed. The spreader/riving knife must be in alignment front to back (horizontally) and top to bottom (vertically).

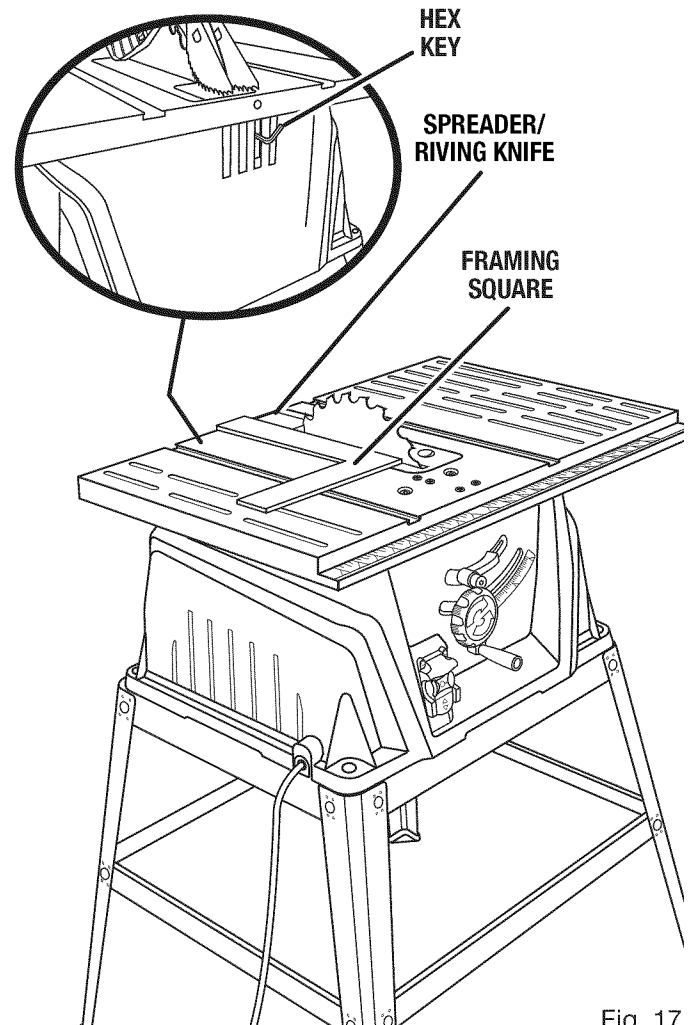

Fig. 17

ASSEMBLY

To adjust (horizontally):

- Remove the blade guard assembly and anti-kickback pawls.
- Raise the blade to its full height.
- Insert the hex key through the slot on the back of the saw. Two adjustment screws can be accessed through the slot.
- Turn the adjustment screws to reposition the spreader/riving knife left or right as needed to align the spreader/riving knife with the saw blade.
- Once properly aligned, securely retighten the screws.

To adjust (vertically):

- Push either side of the riving knife to align it top to bottom with the blade. Check its position after adjustment to ensure that it is vertically aligned with the blade.

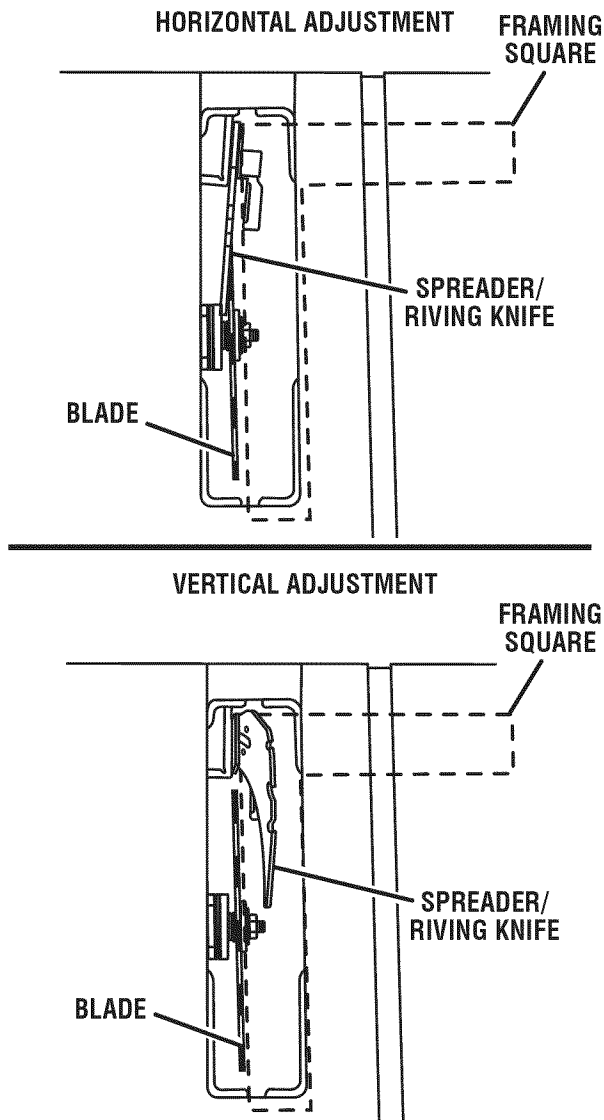

Fig. 18

PUSH STICK STORAGE

See Figure 19.

- Insert the push stick storage screws from the loose parts bag into the holes on the side of the saw table. Use a Phillips head screwdriver to tighten screws securely.
- Place the slots in the push stick over the screws and slide the push stick toward the back of the saw.

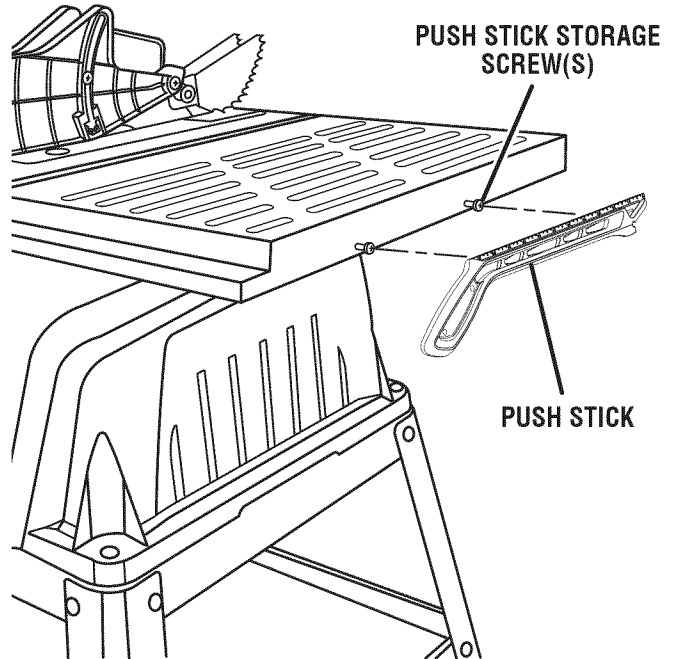

Fig. 19

OPERATION

⚠ WARNING: Do not allow familiarity with tools to make you careless. Remember that a careless fraction of a second is sufficient to inflict severe injury.

⚠ WARNING: Always wear eye protection with side shields marked to comply with ANSI Z87.1. Failure to do so could result in objects being thrown into your eyes, resulting in possible serious injury.

⚠ WARNING: Do not use any attachments or accessories not recommended by the manufacturer of this tool. The use of attachments or accessories not recommended can result in serious personal injury.

⚠ WARNING: Although many of the illustrations in this manual are shown with the blade guard removed for clarity, do not operate the saw without the blade guard unless specifically instructed to do so.

APPLICATIONS

You may use this tool for the purposes listed below:

- Straight line cutting operations such as cross cutting, ripping, mitering, beveling, and compound cutting
- Cabinet making and woodworking

NOTE: This table saw is designed to cut wood and wood composition products only. It is not designed for cutting large panels. Depending on the shape of the panel, use the rip fence or miter gauge. If the panel is too large to use either the rip fence or the miter gauge, it is too large for this saw.

BASIC OPERATION OF THE TABLE SAW

The 3-prong plug must be plugged into a matching outlet that is properly installed and grounded according to all local codes and ordinances. Improper connection of the equipment can result in electric shock. Do not modify the plug if it will not fit the outlet. Have the correct outlet installed by a qualified electrician. Refer to the *Electrical* section in this manual.

CAUSES OF KICKBACK

Kickback can occur when the blade stalls or binds, kicking the workpiece back toward you with great force and speed. If your hands are near the saw blade, they may be jerked loose from the workpiece and may contact the blade. Kickback can cause serious injury. Use precautions to avoid the risks.

Kickback can be caused by any action that pinches the blade in the wood such as:

- Making a cut with incorrect blade depth
- Sawing into knots or nails in the workpiece
- Twisting the wood while making a cut
- Failing to support work
- Forcing a cut
- Cutting warped or wet lumber
- Using the wrong blade for the type of cut
- Not following correct operating procedures
- Misusing the saw
- Failing to use the anti-kickback pawls
- Cutting with a dull, gummed-up, or improperly set blade

AVOIDING KICKBACK

- Always use the correct blade depth setting. The top of the blade teeth should clear the workpiece by 1/8 in. to 1/4 in.
- Inspect the work for knots or nails before beginning a cut. Knock out any loose knots with a hammer. Never saw into a loose knot or nail.
- Always use the rip fence when rip cutting. Use the miter gauge when cross cutting. This helps prevent twisting the wood in the cut.
- Always use clean, sharp, and properly-set blades. Never make cuts with dull blades.
- To avoid pinching the blade, support the work properly before beginning a cut.
- When making a cut, use steady, even pressure. Never force cuts.
- Do not cut wet or warped lumber.
- Use extra caution when cutting some prefinished or composition wood products as the anti-kickback pawls may not always be effective.
- Always guide your workpiece with both hands or with push sticks and/or push blocks. Keep your body in a balanced position to be ready to resist kickback should it occur. Never stand directly in line with the blade.
- Use of a featherboard will help hold the workpiece securely against the saw table or fence.
- Clean the saw, blade guard, under the throat plate, and any areas where saw dust or scrap workpieces may gather.
- Use the right type of blade for the cut being made.
- Always use the spreader / riving knife for every operation where it is allowed. The use of this device will greatly reduce the risk of kickback.

OPERATION

CUTTING AIDS

See Figure 20.

Push sticks are devices that may be used for pushing a workpiece through the blade in any rip cut. When making non-through cuts or ripping narrow stock, always use a push stick, push block, and/or featherboard so your hands do not come within 3 inches of the saw blade. They can be made in various sizes and shapes from scrap wood and used in a specific project. The stick must be narrower than the workpiece, with a 90° notch in one end and shaping for a grip on the other end.

A push block has a handle fastened by recessed screws from the underside. Use push blocks for narrow cuts and all non-through cuts.

CAUTION: Be sure the screws in a push block are recessed to avoid damaging the saw or workpiece.

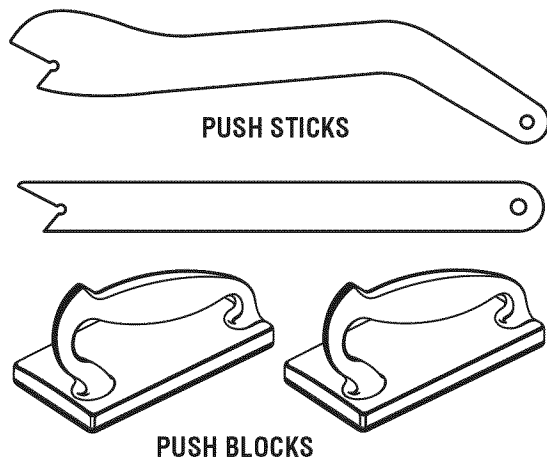

Fig. 20

AUXILIARY FENCE

An auxiliary fence is a device used to close the gap between the rip fence and the saw table. Always make and use an auxiliary fence when ripping material 1/8 in. or thinner.

HOW TO MAKE AND ATTACH AN AUXILIARY FENCE (FOR RIP CUTTING THIN WORKPIECE)

See Figure 21.

Rip fence holes are used to secure an auxiliary fence which requires a piece of wood 3/4 in. thick, 3-1/2 in. wide, and 18-1/2 in. long to make.

To attach the auxiliary fence to the rip fence:

Place the wood against the rip fence and resting firmly on the saw table.

- From the back side of the rip fence, secure the wood to the fence using 1-1/2 in. wood screws.

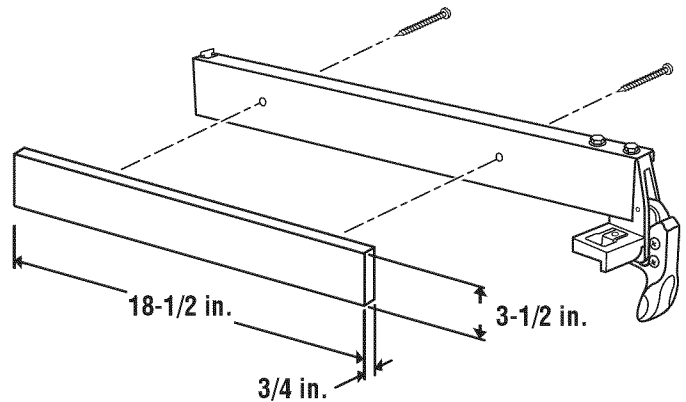

Fig. 21

HOW TO MAKE A JIG (FOR RIP CUTTING NARROW WORKPIECE)

See Figure 22.

If ripping a narrow workpiece places the hands too close to the blade, it will be necessary to make and use a jig.

To make a jig:

- Attach a handle to a long, straight piece of wood and secure from the underside using recessed screws.
- Cut an L-shaped stop in the side of the jig.

To use a jig:

- Position the workpiece flat on the table with the edge flush against the jig and against the stop.
- Holding the jig handle and using a push block, make the rip cut as described on page 32 later in this section.

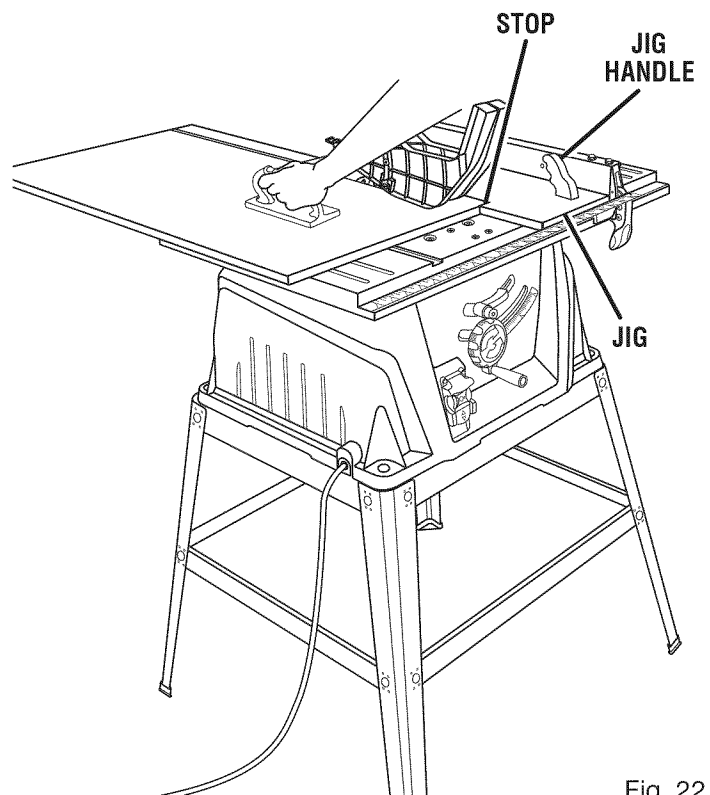

Fig. 22

OPERATION

FEATHERBOARD

A featherboard is a device used to help control the workpiece by holding it securely against the table or fence. Featherboards are especially useful when ripping small workpieces and for completing non-through cuts. The end is angled with a number of short kerfs to give a friction hold on the workpiece and locked in place on the table with a C-clamp. Test to ensure it can resist kickback.

HOW TO MAKE A FEATHERBOARD

See Figure 23.

The featherboard is an excellent project for the saw. Select a solid piece of lumber approximately 3/4 in. thick, 2-1/2 in. wide and 12 in. long. Mark the center of the width on one end of the stock. Miter the width to 70° (see page 32 for information on miter cuts).

Prepare the saw for ripping as discussed on page 32. Set the rip fence to allow approximately a 1/4 in. "finger" to be cut in the stock. Feed the stock only to the mark previously made at 6 in. Turn the saw **OFF** and allow the blade to completely stop rotating before removing the stock. Reset the rip fence and cut spaced rips into the workpiece to allow approximately 1/4 in. fingers and 1/8 in. spaces between the fingers.

⚠ WARNING: Mount the featherboard in front of the saw blade. If positioned improperly, kickback can result from the featherboard pinching the workpiece and binding the blade in the saw kerf. Failure to heed this warning can result in serious personal injury.

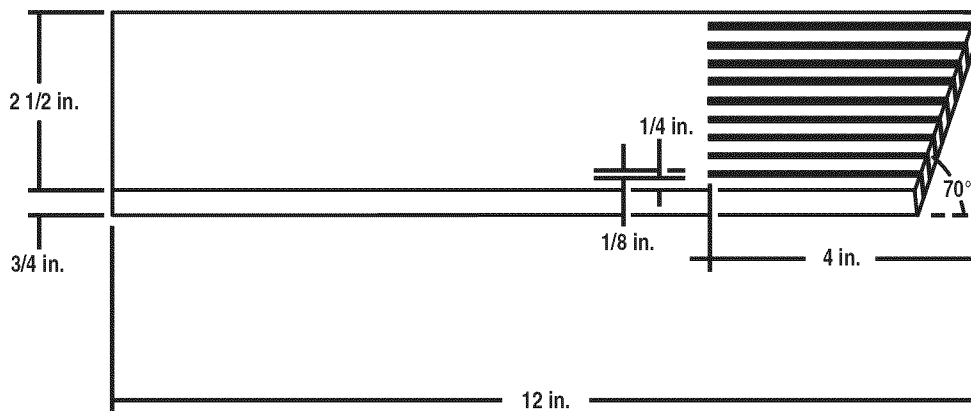

Fig. 23

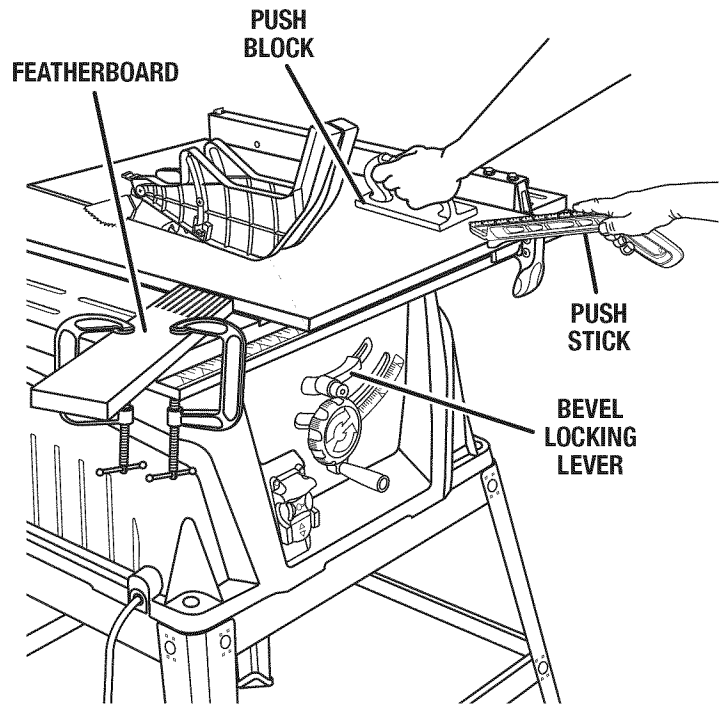

Fig. 24

HOW TO MOUNT A FEATHERBOARD

See Figure 24.

Completely lower the saw blade. Position the rip fence to the desired adjustment for the cut to be performed and lock. Place the workpiece against the fence and over the saw blade area. Adjust the featherboard to apply resistance to the workpiece just forward of the blade. Securely tighten the adjusting clamp knob to secure the featherboard in place. Attach C-clamps to further secure the featherboard to the edge of the saw table.

OPERATION

TYPES OF CUTS

See Figure 25.

There are six basic cuts: 1) the cross cut, 2) the rip cut, 3) the miter cut, 4) the bevel cross cut, 5) the bevel rip cut, and 6) the compound (bevel) miter cut. All other cuts are combinations of these basic six. Operating procedures for making each kind of cut are given later in this section.

⚠ WARNING: Always make sure the blade guard and anti-kickback pawls are in place and working properly when making these cuts to avoid possible injury.

Cross cuts are straight 90° cuts made across the grain of the workpiece. The wood is fed into the cut at a 90° angle to the blade, and the blade is vertical.

Rip cuts are made with the grain of the wood. To avoid kickback while making a rip cut, make sure one side of the wood rides firmly against the rip fence.

Miter cuts are made with the wood at any angle to the blade other than 90°. The blade is vertical. Miter cuts tend to “creep” during cutting. This can be controlled by holding the workpiece securely against the miter gauge.

Bevel cuts are made with an angled blade. Bevel cross cuts are across the wood grain, and bevel rip cuts are with the grain.

Compound (or bevel) miter cuts are made with an angled blade on wood that is angled to the blade. Be thoroughly familiar with making cross cuts, rip cuts, bevel cuts, and miter cuts before trying a compound miter cut.

CUTTING TIPS

Rabbet cuts are non-through cuts which can be either rip cuts or cross cuts. Carefully read and understand all sections of this operator’s manual before attempting any operation.

⚠ WARNING: Do not use blades rated less than the speed of this tool. Failure to heed this warning could result in personal injury.

- The kerf (the cut made by the blade in the wood) will be wider than the blade to avoid overheating or binding. Make allowance for the kerf when measuring wood.
- Make sure the kerf is made on the waste side of the measuring line.
- Cut the wood with the finish side up.
- Knock out any loose knots with a hammer before making the cut.
- Always provide proper support for the wood as it comes out of the saw.

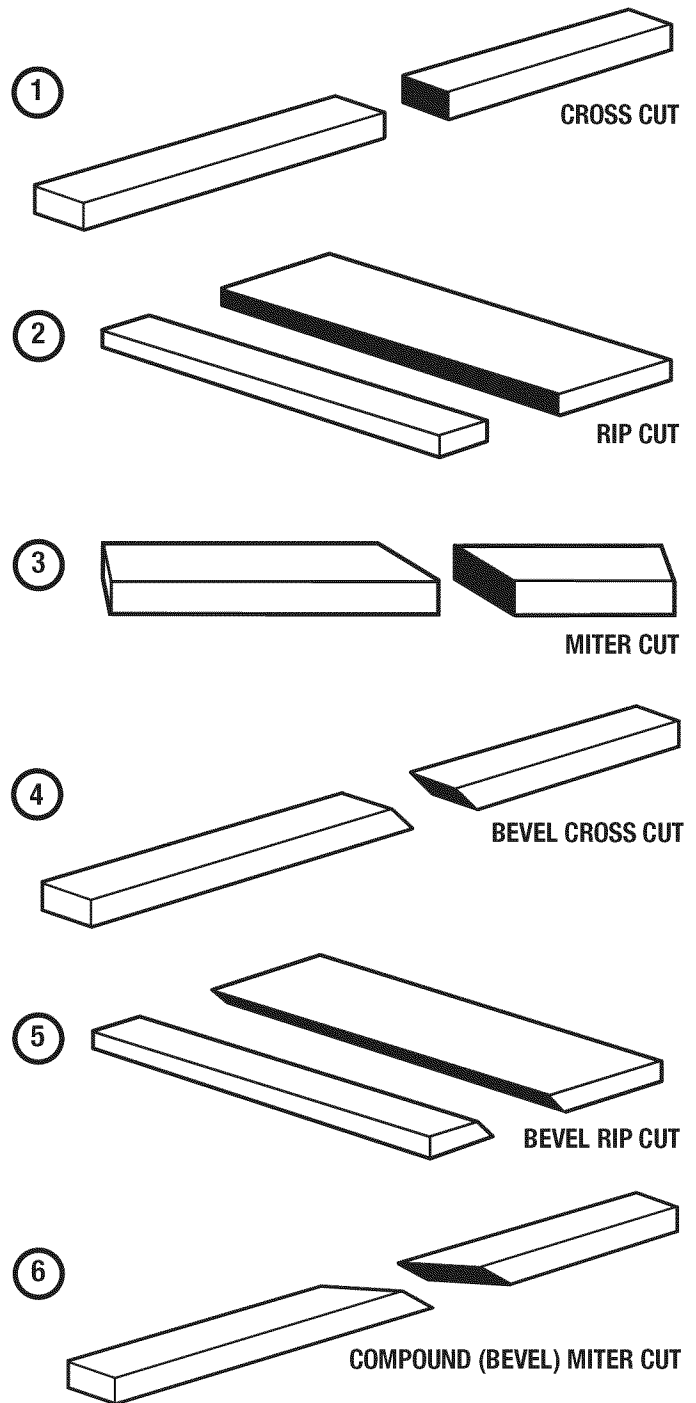

Fig. 25

OPERATION

TO CHANGE BLADE DEPTH

See Figure 26.

The blade depth should be set so that the outer points of the blade are higher than the workpiece by approximately 1/8 in. to 1/4 in. but the lowest points (gullets) are below the top surface.

- Turn the bevel lock lever to the right.
- Raise the blade by turning the height/bevel adjusting handwheel clockwise or lower it by turning the handwheel counterclockwise.

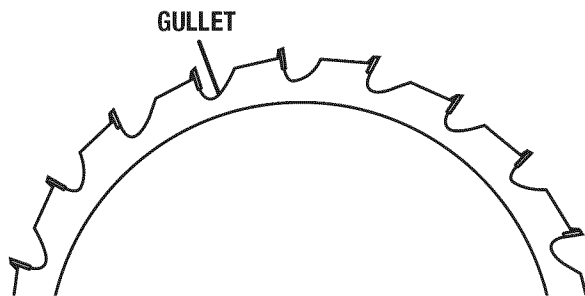

Fig. 26

TO CHANGE BLADE ANGLE (BEVEL)

See Figure 27.

This table saw has a rack and pinion bevel control that allows you to make angled cuts from 90° to 45°.

NOTE: A 90° cut has a 0° bevel and a 45° cut has a 45° bevel.

- Unplug the saw.
- Loosen bevel control by turning bevel lock lever all the way to the left. If it needs to be further loosened, pull spring-loaded bevel lock lever out and rotate it back to the right. Release bevel locking lever and allow it to seat (lock) in its original position. Turn it to the left again until loose.
- Move the height adjusting handwheel to the right to bevel to 45° bevel angle.
- Tighten bevel control by turning bevel lock lever to the right. If it needs to be tightened more, pull the spring-loaded bevel lock lever out and rotate it to the left. Then release bevel lock lever and allow it to return to its original position. Rotate to the right again. Repeat this process until bevel lock lever is securely tightened.

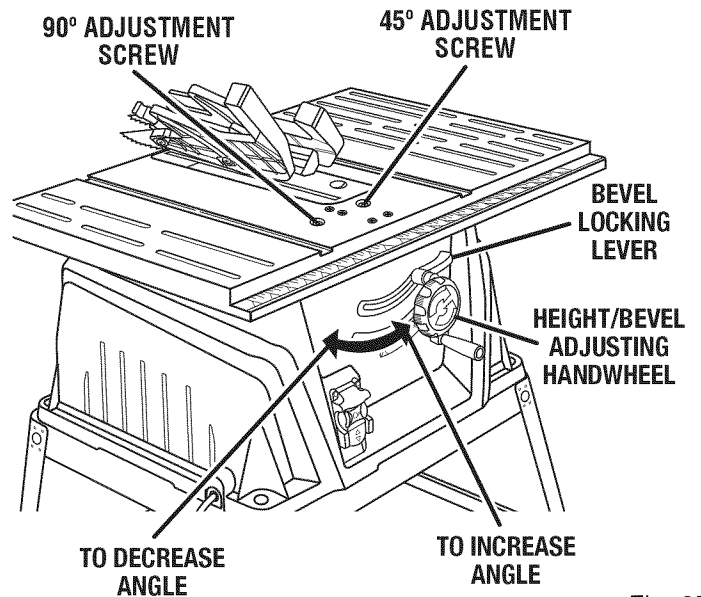

Fig. 27

TO ADJUST THE BEVEL INDICATOR

See Figure 28.

If the bevel indicator is not at zero when the saw blade is at 90°, adjust the indicator by loosening the screw and setting it at 0° on the bevel scale. Retighten the screw.

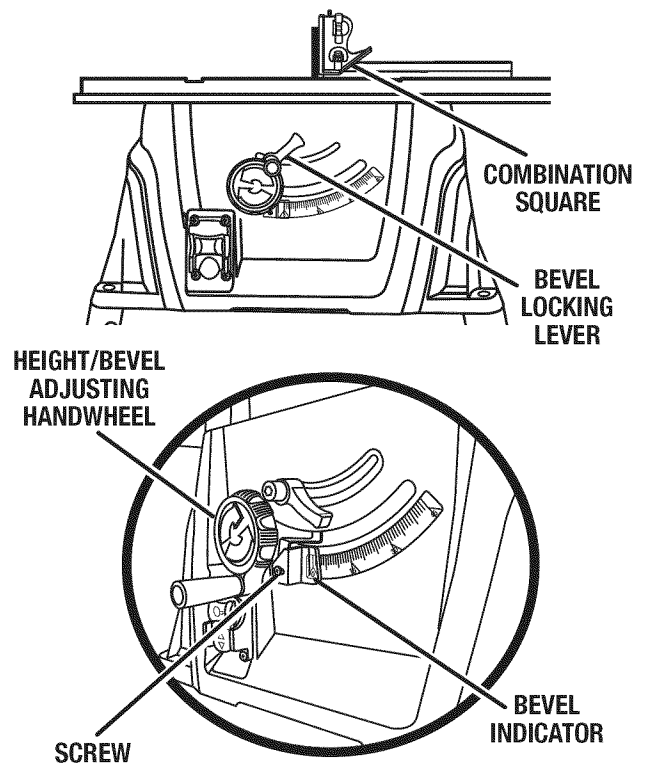

Fig. 28

OPERATION

⚠ WARNING: To reduce the risk of injury, always make sure the rip fence is parallel to the blade before beginning any operation.

TO USE THE RIP FENCE

See Figure 29.

- Place the rear lip on the rear of the saw table and pull slightly toward the front of the unit.
- Lower the front end of the rip fence onto the guide surfaces on top of the front rail.
- With the rip fence flat on the saw table, push the fence towards the front rail to align the fence to the saw table.
- Push the locking lever down to align and secure the fence.

Check for a smooth gliding action. If adjustments are needed, see **To Check the Alignment of the Rip Fence to the Blade** in the *Adjustment* section of this manual.

- Make two or three test cuts on scrap wood. If the cuts are not true, repeat the process.

NOTE: The rip fence must be secure when the locking handle is engaged. To increase the grip of the rip fence on the rear lip of the table, tighten the clamp screw on the rear of the rip fence by turning it clockwise.

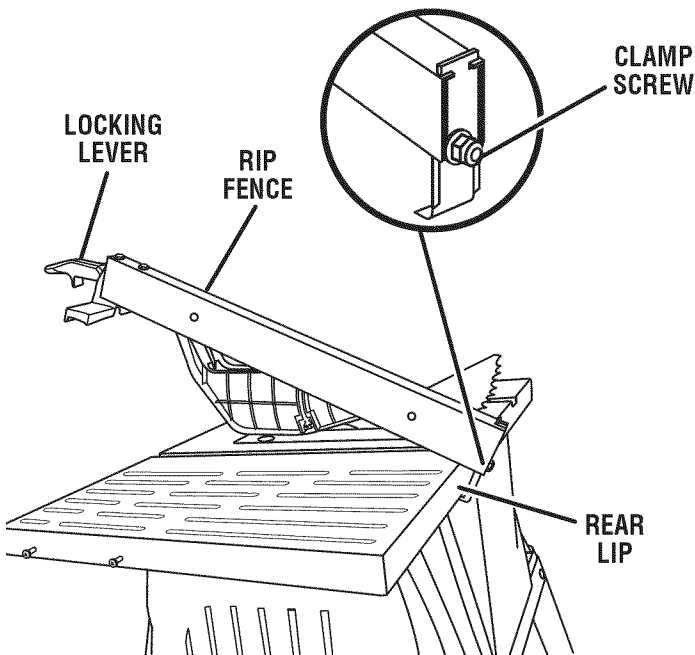

Fig. 29

TO SET THE RIP FENCE SCALE INDICATOR TO THE BLADE

See Figure 30.

Use the indicator on the rip fence to position the fence along the scale on the front rail.

NOTE: The anti-kickback pawls and blade guard assembly must be removed to perform this adjustment. Reinstall the blade guard assembly when the adjustment is complete.

Begin with the blade at a zero angle (straight up).

- Unplug the saw.
- Loosen the rip fence by lifting the locking lever.
- Using a framing square, set the rip fence 2 in. from the blade tip edge.
- Loosen the screw on the scale indicator and align with the 2 in. mark as shown.
- Tighten the screw and check the dimension and the rip fence.

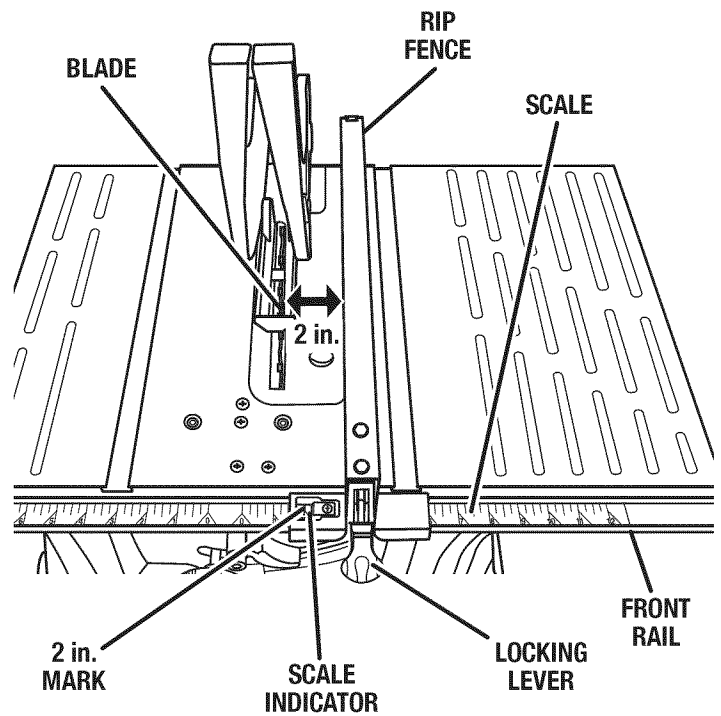

Fig. 30

OPERATION

TO USE THE MITER GAUGE

See Figure 31.

The miter gauge provides greater accuracy in angled cuts. For very close tolerances, test cuts are recommended.

There are two miter gauge grooves, one on either side of the blade. When making a 90° cross cut, you can use either miter gauge groove. When making a beveled cross cut (the blade tilted in relation to the table) the miter gauge should be located in the groove on the right so that the blade is tilted away from the miter gauge and your hands.

The miter gauge can be turned 60° to the right or left.

- Loosen the lock knob.
- With the miter gauge in the miter gauge groove, rotate the gauge until the desired angle is reached on the scale.
- Retighten the lock knob.

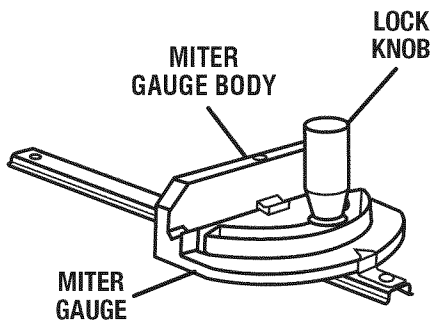

Fig. 31

TO USE THE MITER GAUGE IN A REVERSE POSITION

See Figure 32.

For larger workpieces, the miter gauge can be reversed in the miter gauge grooves. It will be necessary when reversing the miter gauge to clamp the workpiece to the miter gauge body.

MITER GAUGE REVERSED

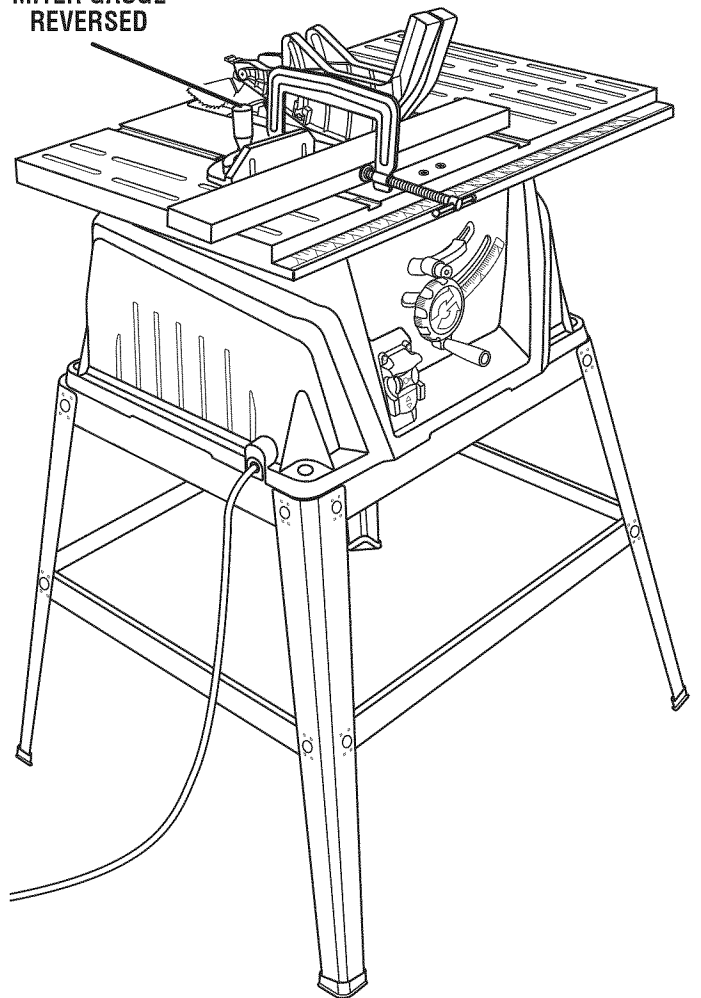

Fig. 32

OPERATION

HEELING (PARALLELING) THE BLADE TO THE MITER GAUGE GROOVE

See Figures 33 - 35.

WARNING: The blade must be parallel to the miter gauge groove so the wood does not bind resulting in kickback. Failure to do so could result in serious personal injury.

Do not loosen any screws for this adjustment until you have checked with a square and made test cuts to be sure adjustments are necessary. Once the screws are loosened, these items must be reset.

- Unplug the saw.
- Remove the blade guard and anti-kickback pawls. Raise the blade by turning the height/bevel adjusting handwheel.
- Mark beside one of the blade teeth at the front of the blade. Place a combination square even with the front of the saw table and the side of the saw blade as shown in figure 33.
- Turn the blade so the marked tooth is at the back.
- Move the combination square to the rear and again measure the distance. If the distances are the same, the blade is square.

If the distances are different:

- Place spreader/riving knife in "down" position.
- Loosen the adjusting screws, located on top of the saw table.

NOTE: If the back of the blade was too far from the combination square, place a block of wood on the left side of the blade and push it into the blade until the blade is square. Retighten the screws.

- If the back of the blade was too close to the combination square, place a block of wood on the right side of the blade and push it into the blade until the blade is square.

- Retighten the screws.

WARNING: To reduce the risk of injury from kickback, align the rip fence to the blade following any blade adjustments. Always make sure the rip fence is parallel to the blade before beginning any operation.

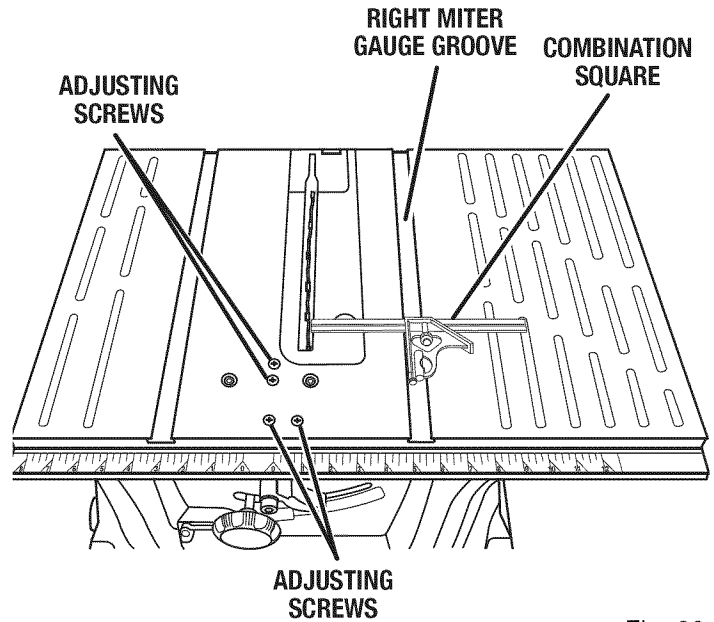

Fig. 33

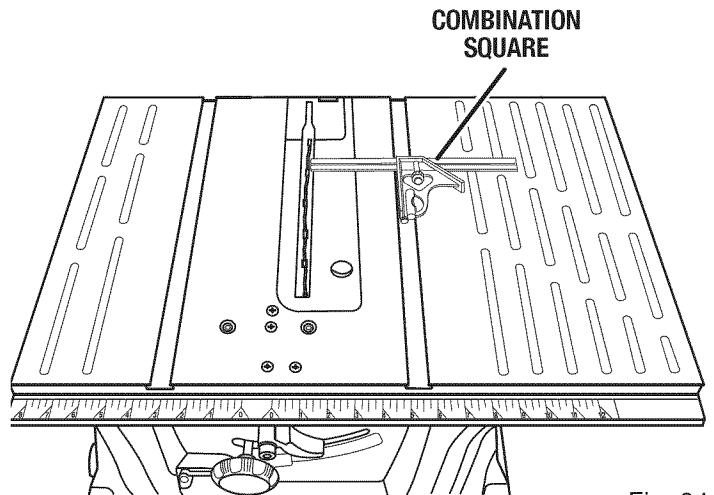
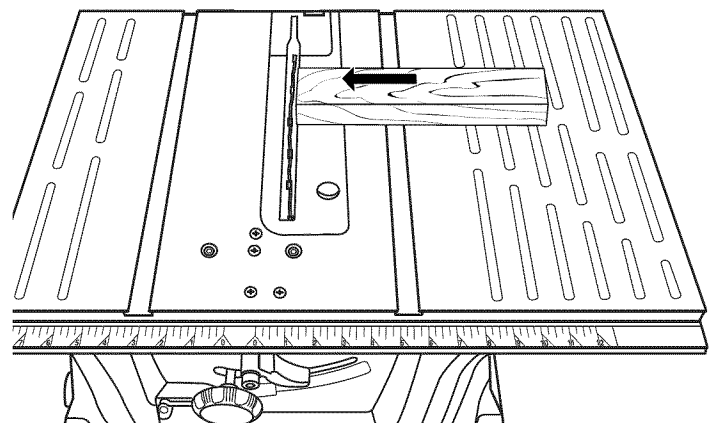

Fig. 34



BLADE TOO CLOSE TO MITER GAUGE GROOVE

Fig. 35

OPERATION

MAKING CUTS

This table saw can perform a variety of cuts that are not all mentioned in this manual. DO NOT attempt to make any cuts not covered here unless you are thoroughly familiar with the proper procedures and necessary accessories. Your local library has many books on table saw usage and specialized woodworking procedures for your reference.

The blade provided with the saw is a high-quality combination blade suitable for ripping and cross cut operations. Carefully check all setups and rotate the blade one full revolution to assure proper clearance before connecting saw to power source. Stand slightly to the side of the blade path to reduce the chance of injury should kickback occur.

⚠ WARNING: Do not use blades rated less than the speed of this tool. Failure to heed this warning could result in personal injury.

Use the miter gauge when making cross, miter, bevel, and compound miter cuts. To secure the angle, lock the miter gauge in place by twisting the lock knob clockwise. Always tighten the lock knob securely in place before use.

NOTE: It is recommended that you place the piece to be saved on the left side of the blade and that you make a test cut on scrap wood first.

MAKING A CROSS CUT

See Figures 36 - 37.

⚠ WARNING: Make sure the blade guard assembly is installed and working properly to avoid serious possible injury.

⚠ WARNING: Using the rip fence as a cutoff gauge when cross cutting will result in kickback which can cause serious personal injury.

- Remove the rip fence.
- Set the blade to the correct depth for the workpiece.
- Set the miter gauge to 0° and tighten the lock knob.
- Make sure the wood is clear of the blade before turning on the saw.
- Turn the saw on.
- Let the blade build up to full speed before moving the workpiece into the blade.
- Hold the workpiece firmly with both hands on the miter gauge and feed the workpiece into the blade.

NOTE: The hand closest to the blade should be placed on the miter gauge lock knob and the hand farthest from the blade should be placed on the workpiece.

- When the cut is made, turn the saw off. Wait for the blade to come to a complete stop before removing the workpiece.

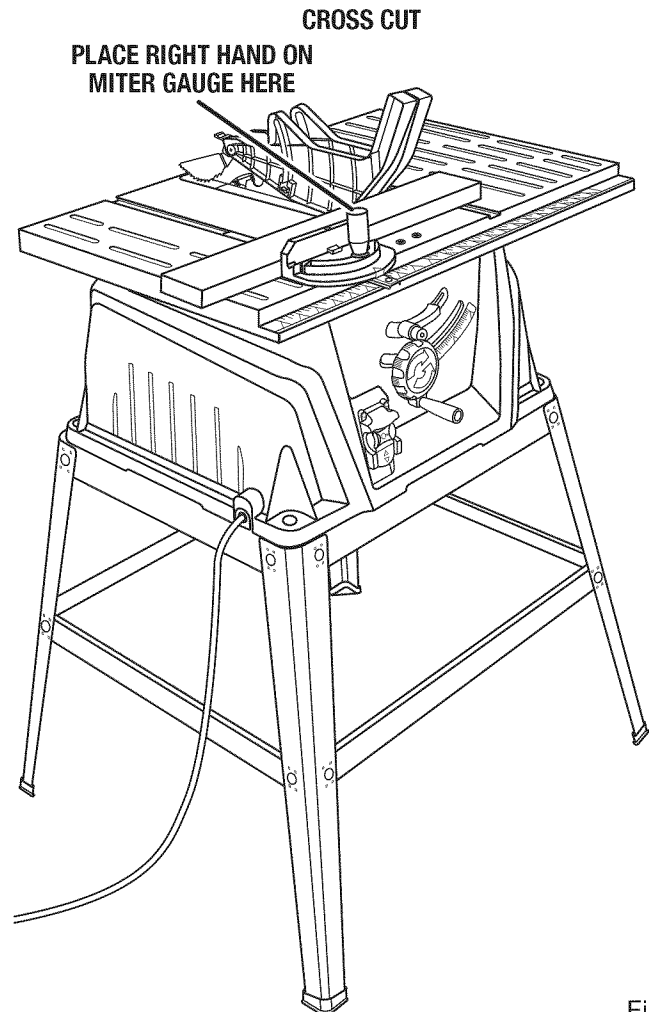
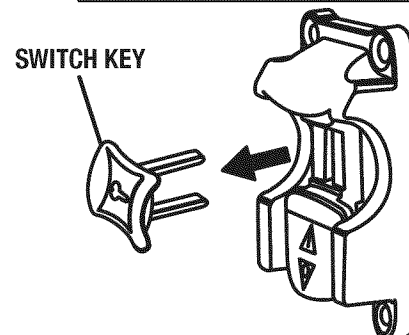
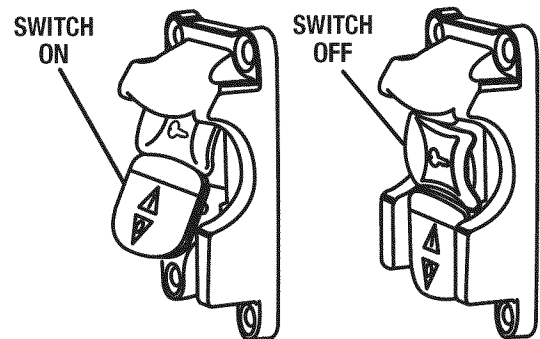

Fig. 36



SWITCH IN LOCKED POSITION

Fig. 37

OPERATION

MAKING A RIP CUT

See Figure 38.

- ▲ **WARNING:** Make sure the blade guard assembly is installed and working properly to avoid serious possible injury.
- Set the blade to the correct depth for the workpiece.
- Position the rip fence the desired distance from the blade for the cut and securely lock the handle.
- Make sure the wood is clear of the blade before turning on the saw.
- When ripping a long workpiece, place a support the same height as the table surface behind the saw for the cut work.
- Turn the saw on.
- Position the workpiece flat on the table with the edge flush against the rip fence. Let the blade build up to full speed before feeding the workpiece into the blade.
- Once the blade has made contact with the workpiece, use the hand closest to the rip fence to guide it. Make sure the edge of the workpiece remains in solid contact with both the rip fence and the surface of the table. If ripping a narrow piece, use a push stick and/or push blocks to move the piece through the cut and past the blade.
- When the cut is made, turn the saw off. Wait for the blade to come to a complete stop before removing the workpiece.

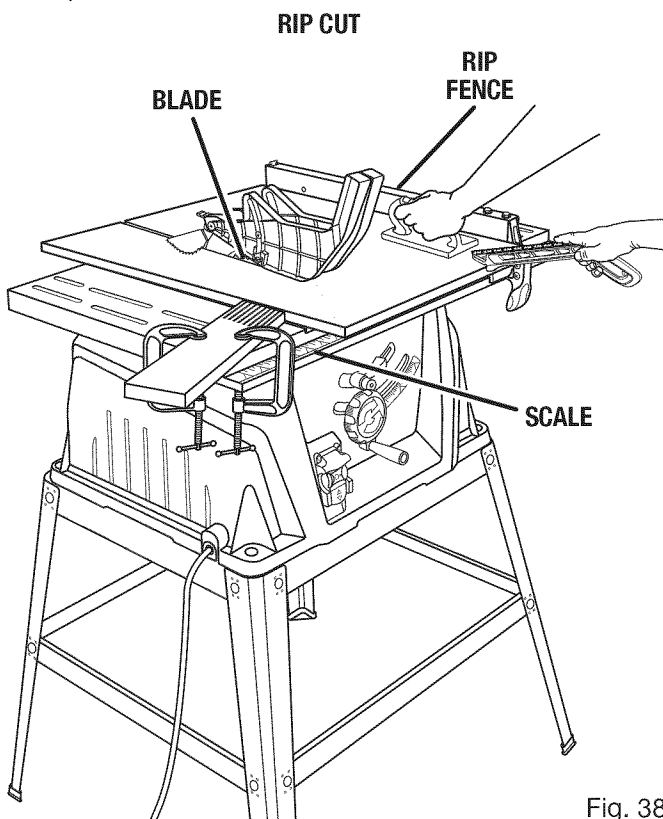

Fig. 38

MAKING A MITER CUT

See Figure 39.

- ▲ **WARNING:** Make sure the blade guard assembly is installed and working properly to avoid possible serious injury.
- Remove the rip fence.
- Set the blade to the correct depth for the workpiece.
- Set the miter gauge to the desired angle and tighten the lock knob.
- Make sure the wood is clear of the blade before turning on the saw.
- Turn the saw on.
- Let the blade build up to full speed before moving the workpiece into the blade.
- Hold the workpiece firmly with both hands on the miter gauge and feed the workpiece into the blade.
- **NOTE:** The hand closest to the blade should be placed on the miter gauge lock knob and the hand farthest from the blade should be placed on the workpiece.
- When the cut is made, turn the saw off. Wait for the blade to come to a complete stop before removing the workpiece.

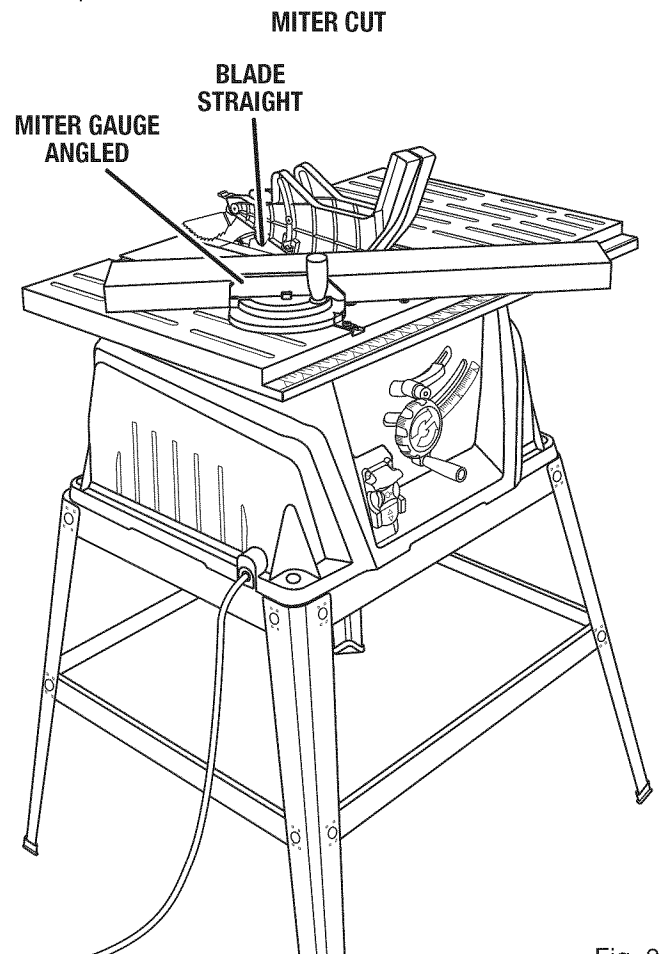

Fig. 39

OPERATION

MAKING A BEVEL CROSS CUT

See Figures 40 - 41.

WARNING: Make sure the blade guard assembly is installed and working properly to avoid possible serious injury.

WARNING: The miter gauge must be on the left side of the blade to avoid trapping the wood and causing kickback and the risk of serious personal injury.

- Remove the rip fence.
- Unlock the bevel locking lever.
- Adjust the bevel angle to the desired setting.
- Lock the bevel locking lever.
- Set the blade to the correct depth for the workpiece.
- Set the miter gauge to 0° and tighten the lock knob.
- Make sure the wood is clear of the blade before turning on the saw.
- Turn the saw on.
- Let the blade build up to full speed before moving the workpiece into the blade.
- Hold the workpiece firmly with both hands on the miter gauge and feed the workpiece into the blade.

VIEWED FROM THE FRONT, BELOW THE TABLE SAW

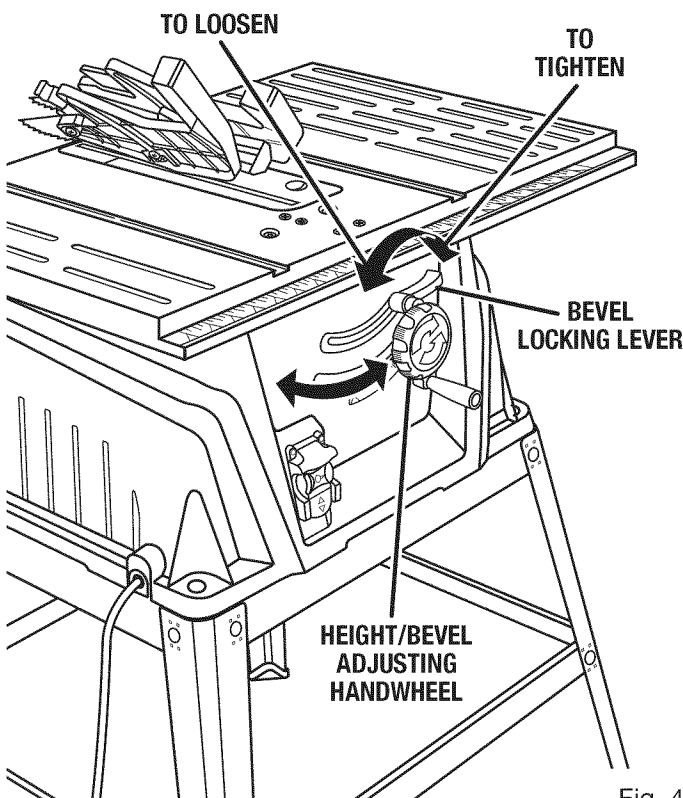

Fig. 40

BEVEL CROSS CUT

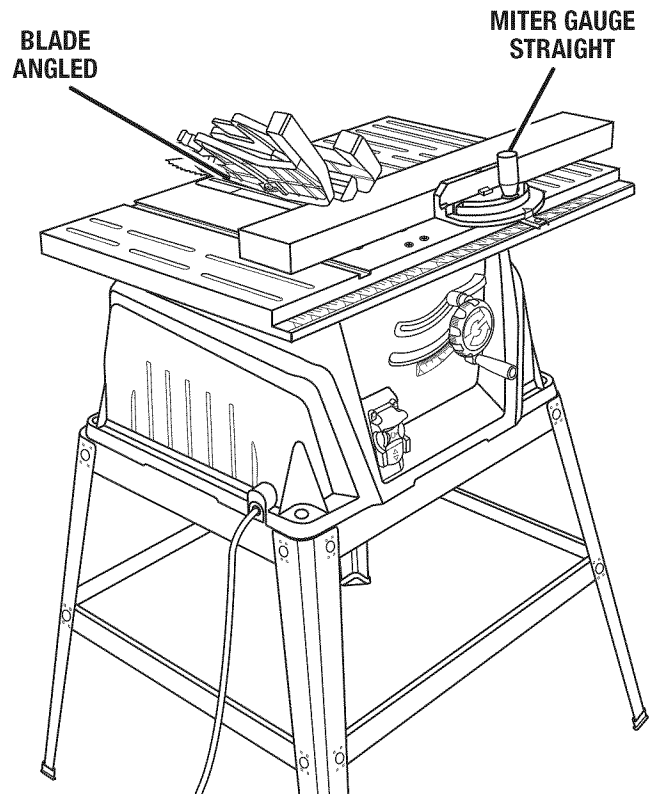

Fig. 41

NOTE: The hand closest to the blade should be placed on the miter gauge lock knob and the hand farthest from the blade should be placed on the workpiece.

- When the cut is made, turn the saw off. Wait for the blade to come to a complete stop before removing the workpiece.

MAKING A BEVEL RIP CUT

See Figure 42.

WARNING: Make sure the blade guard assembly is installed and working properly to avoid serious personal injury.

WARNING: The rip fence must be on the right side of the blade to avoid trapping the wood and causing kickback. Placement of the rip fence to the left of the blade will result in kickback and the risk of serious personal injury.

- Remove the miter gauge.
- Unlock the bevel locking lever.
- Adjust the bevel angle to 0°.
- Lock the bevel locking lever.
- Set the blade to the correct depth for the workpiece.
- Position the rip fence the desired distance from the blade for the cut and securely lock the handle.

OPERATION

- Make sure the wood is clear of the blade before turning on the saw.
- When ripping a long workpiece, place a support the same height as the table surface behind the saw for the cut work.
- Turn the saw on.
- Position the workpiece flat on the table with the edge flush against the rip fence. Let the blade build up to full speed before feeding the workpiece into the blade.
- Once the blade has made contact with the workpiece, use the hand closest to the rip fence to guide it. Make sure the edge of the workpiece remains in solid contact with both the rip fence and the surface of the table. If ripping a narrow piece, use a push stick and/or push blocks to move the piece through the cut and past the blade.
- When the cut is made, turn the saw off. Wait for the blade to come to a complete stop before removing the workpiece.

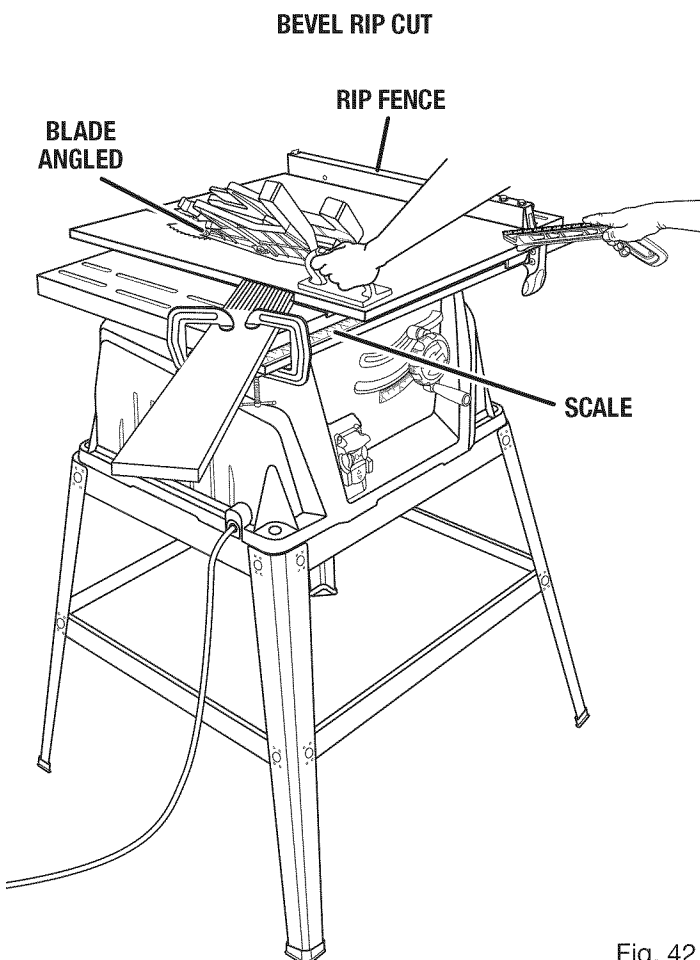

Fig. 42

MAKING A COMPOUND (BEVEL) MITER CUT

See Figure 43.

WARNING: Make sure the blade guard assembly is installed and working properly to avoid possible serious injury.

WARNING: The miter gauge must be on the left side of the blade to avoid trapping the wood and causing kickback and the risk of serious personal injury.

- Remove the rip fence.
 - Unlock the bevel locking lever.
 - Adjust the bevel angle to the desired setting.
 - Lock the bevel locking lever.
 - Set the blade to the correct depth for the workpiece.
 - Set the miter gauge to the desired angle and tighten the lock knob.
 - Make sure the wood is clear of the blade before turning on the saw.
 - Turn the saw on.
 - Let the blade build up to full speed before moving the workpiece into the blade.
 - Hold the workpiece firmly with both hands on the miter gauge and feed the workpiece into the blade.
- NOTE:** The hand closest to the blade should be placed on the miter gauge lock knob and the hand farthest from the blade should be placed on the workpiece.
- When the cut is made, turn the saw off. Wait for the blade to come to a complete stop before removing the workpiece.

COMPOUND (BEVEL) MITER CUT

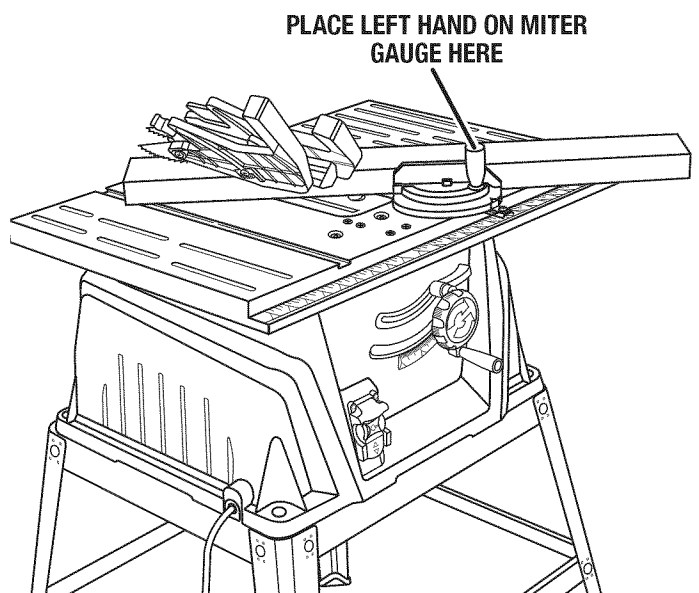

Fig. 43

OPERATION

MAKING A NON-THROUGH CUT

See Figure 44.

WARNING: DO NOT install dado blades on this machine. The arbor shaft has insufficient threads to mount a dado blade. Mounting a dado blade could result in the risk of serious personal injury.

Non-through cuts (made with a standard 10 in. blade) can be made with the grain (ripping) or across the grain (cross cut). The use of a non-through cut is essential to cutting grooves. **DO NOT** perform bevel non-through cuts on this machine.

This is the only type cut that is made without the blade guard assembly installed. Make sure the blade guard assembly is reinstalled upon completion of this type of cut.

Read the appropriate section which describes the type of cut in addition to this section on non-through cuts. For example, if your non-through cut is a straight cross cut, read and understand the section on straight cross cuts before proceeding.

WARNING: When making a non-through cut, the blade is covered by the workpiece during most of the cut. Be alert to the exposed blade at the start and finish of every cut to reduce the risk of personal injury.

WARNING: Never feed wood with your hands when making any non-through cut such as rabbets. To avoid personal injury, always use push blocks, push sticks, and featherboards.

- Unplug the saw.
- Remove the blade guard and anti-kickback pawls.
- Place spreader / riving knife in “down” position.
- Unlock the bevel locking lever.
- Adjust the bevel angle to 0°
- Lock the bevel locking lever.
- Set the blade to the correct depth for the workpiece.
- Depending on the shape and size of the wood, use either the rip fence or miter gauge.

NON-THROUGH CUT

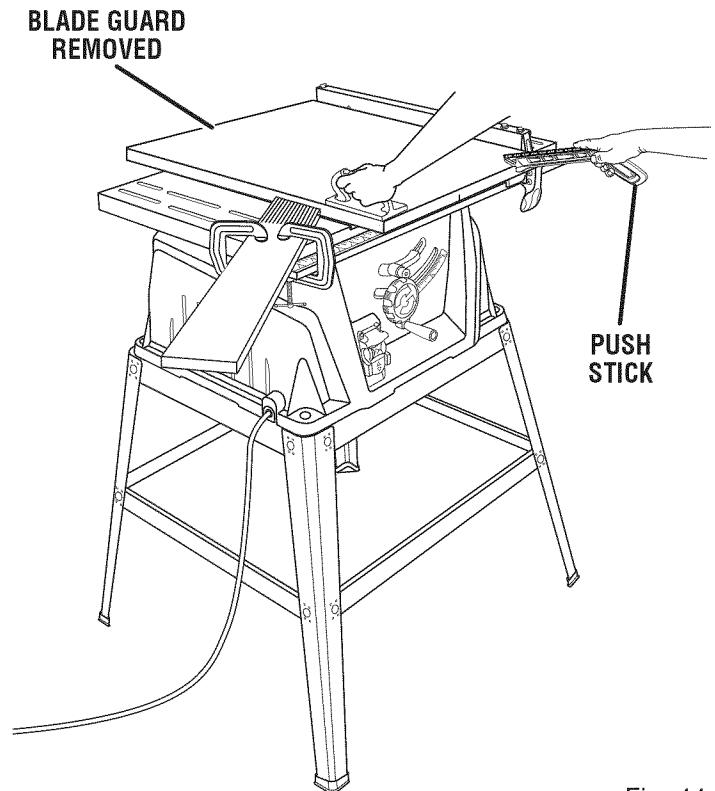

Fig. 44

- Plug the saw into the power source and turn the saw on.
- Let the blade build up to full speed before moving the workpiece into the blade.
- Always use push blocks, push sticks, and/or featherboards when making non-through cuts to reduce the risk of serious injury.
- When the cut is made, turn the saw off. Wait for the blade to come to a complete stop before removing the workpiece.

Once all non-through cuts are completed:

- Unplug your saw.
- Reinstall the spreader/riving knife in the “up” position then install the blade guard and anti-kickback pawls.

ADJUSTMENTS

⚠ WARNING: Before performing any adjustment, make sure the tool is unplugged from the power supply and the switch is in the OFF position. Failure to heed this warning could result in serious personal injury.

The table saw has been adjusted at the factory for making very accurate cuts. However, some of the components might have been jarred out of alignment during shipping. Also, over a period of time, readjustment will probably become necessary due to wear.

To avoid unnecessary set-ups and adjustments, a good practice is to check your setups carefully with a framing square and make practice cuts in scrap wood before making finish cuts in good workpieces. Do not start any adjustments until you have checked with a square and made test cuts to be sure adjustments are needed.

TO REPLACE THE BLADE

See Figures 45 - 47.

- Unplug the saw.
- Remove the blade guard and anti-kickback pawls.
- Lower the saw blade and remove the throat plate.
- Make sure the bevel locking lever is locked.
- Raise the saw blade to full height.
- Insert the open end wrench onto the flats on the arbor shaft.
- Insert the closed end wrench over the blade nut. Holding both wrenches firmly, pull the closed end wrench (right side) forward while pushing the open end wrench (left side) to the back of the saw. Remove the nut.
- Unlock the release locking lever and remove the blade.

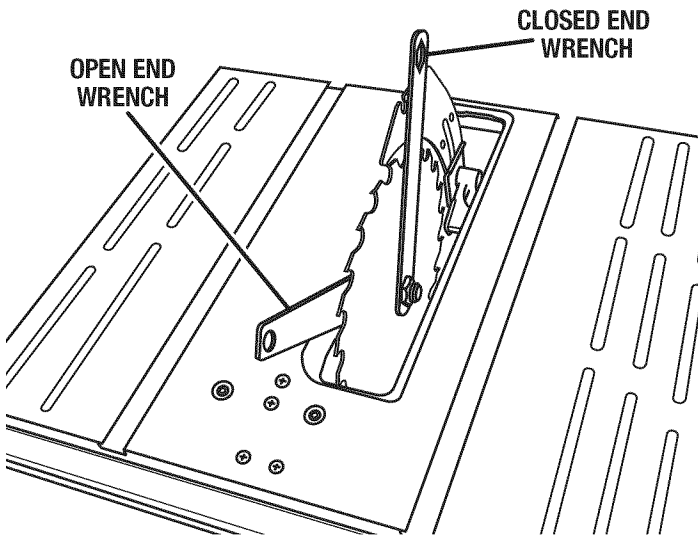

Fig. 45

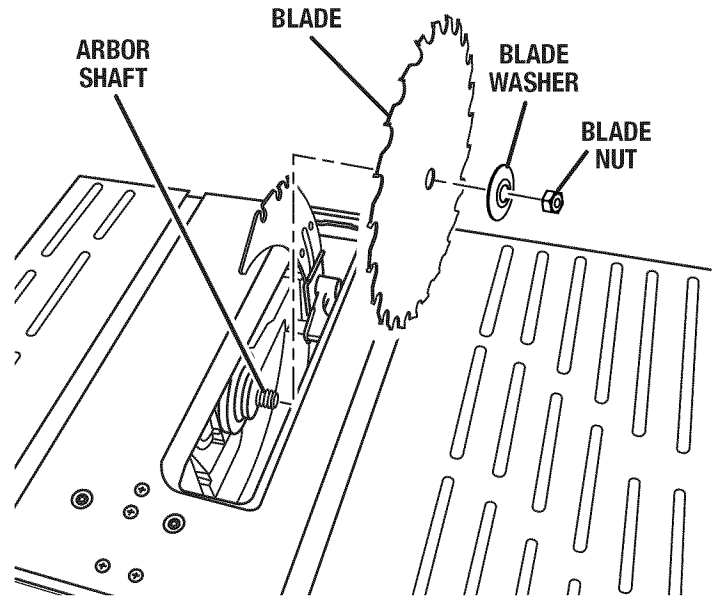

Fig. 46

To install a standard blade:

- Place the new blade on the arbor shaft (the teeth must point down toward the front of the saw to work properly).
- Place the blade washer and the blade nut over the arbor shaft. Be sure the dome side of the blade washer faces the blade and that all items are snug against the arbor housing. Make sure the blade nut is securely tightened. Do not overtighten.
- Lock the release lever.
- Rotate the blade by hand to make sure it turns freely.
- Lower the saw blade and reinstall the throat plate.

NOTE: To replace the blade with an accessory blade, follow the instructions provided with the accessory.

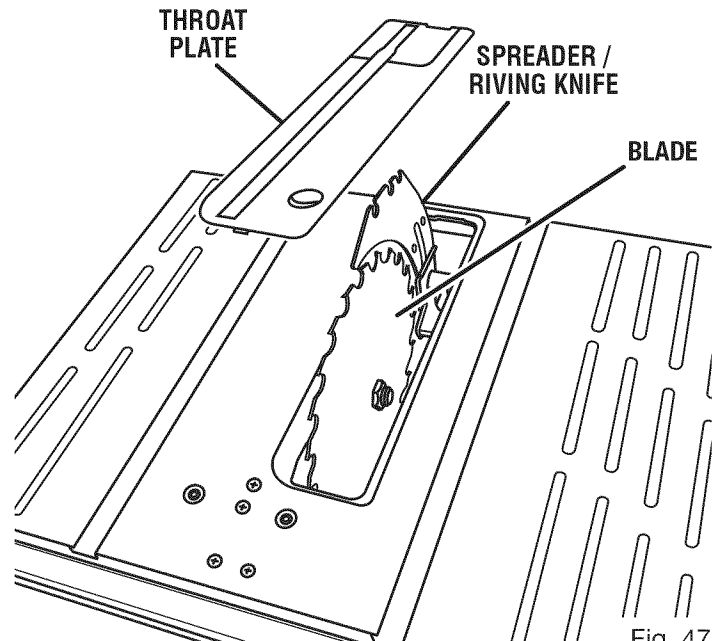

Fig. 47

ADJUSTMENTS

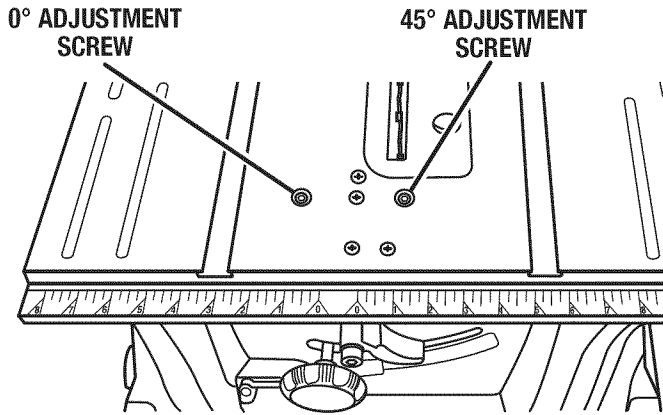

Fig. 48

TO SET THE BLADE AT 0° AND 45°

See Figures 48 - 50.

The angle settings of the saw have been set at the factory and, unless damaged in shipping, should not require setting during assembly. After extensive use, they may need to be checked.

- Unplug the saw.
- Raise the blade.
- Remove the blade guard assembly.

If the blade is not perfectly vertical (0°):

- Loosen the adjustment screw.
- Unlock the bevel locking lever.
- Push the handle to the left side of the slot. Lock the angle by pushing the bevel locking lever.

NOTE: If the handle is pushed as far as possible and doesn't indicate zero properly, you may need to adjust the bevel indicator. It will be necessary to remove the handle to adjust the bevel indicator.

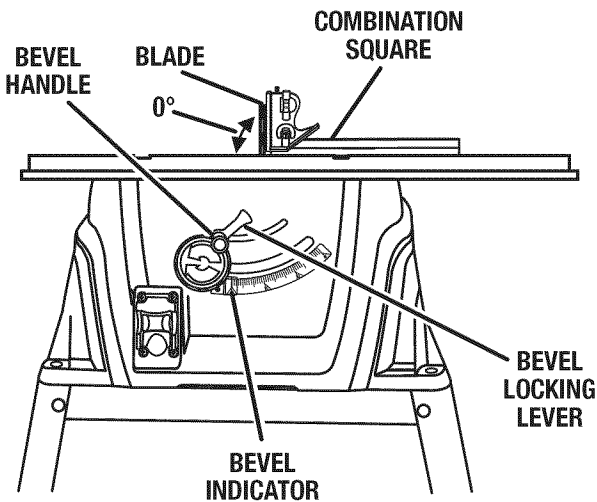

Fig. 49

- Place a combination square beside the blade on the left.
- Turn the 0° adjustment screw until the saw blade starts to move. Check again for squareness and continue to adjust if needed.

If the blade is not an exact 45°:

- Loosen the adjustment screw.
- Unlock the bevel locking lever.
- Push the handle to the right side of the slot. Lock the angle by pushing the bevel locking lever.
- Place a combination square beside the blade on the left.
- Turn the 45° stop screw until the saw blade starts to move. Check again for squareness and continue to adjust if needed.
- If needed, adjust the bevel indicator to 45°.
- Make a test cut.

The adjustment screws must be below the saw table surface so the workpiece doesn't catch on uneven edges.

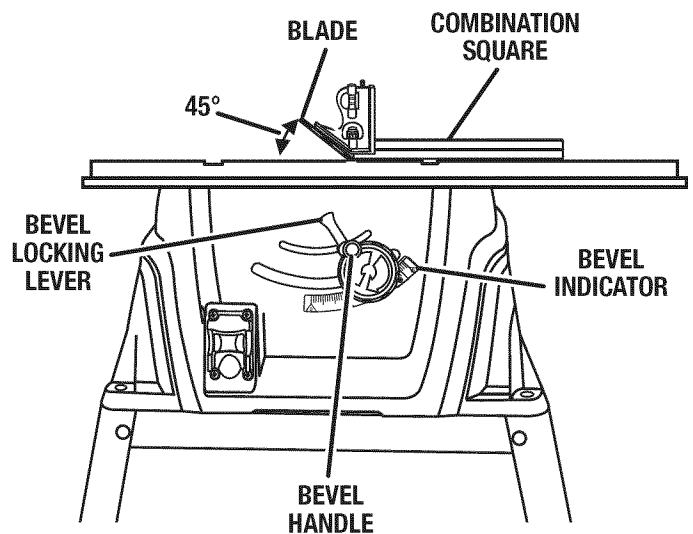

Fig. 50

ADJUSTMENTS

TO CHECK THE ALIGNMENT OF THE RIP FENCE TO THE BLADE

See Figure 51.

- Unplug the saw.
- Raise the locking lever to permit the rip fence to be moved.
- Place a framing square beside the blade and move the rip fence up to the square. Take the dimension on the rip scale.
- Move the fence back and turn the framing square 180° to check the other side.
- If the two dimensions are not the same, loosen the two bolts on the fence and align it.
- Retighten the two bolts.
- Make two or three test cuts on scrap wood. If the cuts are not true, repeat the process.

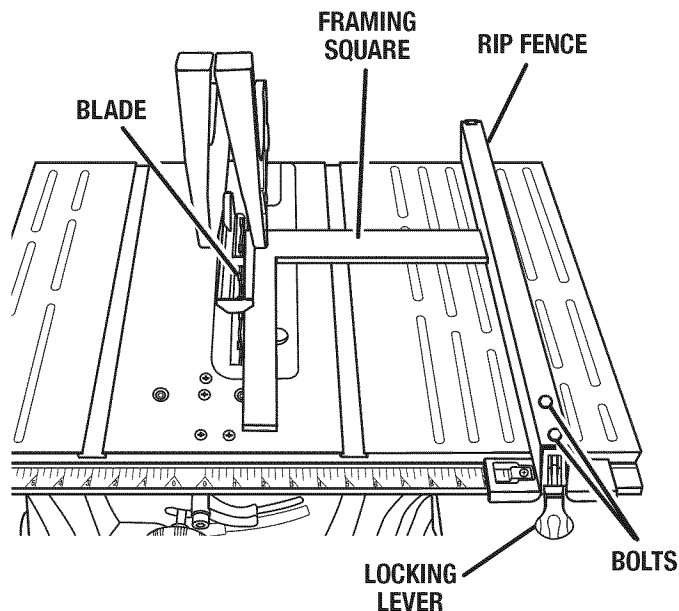

Fig. 51

MAINTENANCE

WARNING: When servicing, use only identical replacement parts. Use of any other parts may create a hazard or cause product damage.

WARNING: Always wear safety goggles or safety glasses with side shields during power tool operation or when blowing dust. If operation is dusty, also wear a dust mask.

WARNING: Before performing any maintenance, make sure the tool is unplugged from the power supply and the switch is in the off (O) position. Failure to heed this warning could result in serious personal injury.

GENERAL MAINTENANCE

Avoid using solvents when cleaning plastic parts. Most plastics are susceptible to damage from various types of commercial solvents and may be damaged by their use. Use clean cloths to remove dirt, dust, oil, grease, etc.

WARNING: Do not at any time let brake fluids, gasoline, petroleum-based products, penetrating oils, etc., come in contact with plastic parts. Chemicals can damage, weaken, or destroy plastic which may result in serious personal injury.

- Periodically check all clamps, nuts, bolts, and screws for tightness and condition. Make sure the throat plate is in good condition and in position.
- Check the blade guard assembly.
- To maintain the table surfaces, fence, and rails, periodically apply paste wax to them and buff to provide smooth functioning.
- Protect the blade by cleaning out sawdust from underneath the table and in the blade teeth. Use a resin solvent on the blade teeth.
- **Clean plastic parts only with a soft damp cloth. DO NOT use any aerosol or petroleum solvents.**

LUBRICATION

All of the bearings in this tool are lubricated with a sufficient amount of high grade lubricant for the life of the unit under normal operating conditions. Therefore, no further lubrication is required.

TROUBLESHOOTING

PROBLEM	CAUSE	SOLUTION
Excess vibration.	Blade is out of balance.	Replace blade.
	Blade is damaged.	Replace blade.
	Saw is not mounted securely.	Tighten all hardware.
	Work surface is uneven.	Reposition on flat surface.
	Blade is warped.	Check saw blade installation. Replace blade if necessary.
Rip fence does not move smoothly.	Rip fence not mounted correctly.	Remount the rip fence.
	Rails are dirty or sticky.	Clean and wax rails.
	Clamp screw is out of adjustment.	Adjust clamp screw counterclockwise.
Rip fence does not lock at rear.	Clamp screw is out of adjustment.	Adjust clamp screw clockwise.
Cutting binds or burns work.	Blade is dull.	Replace or sharpen blade.
	Blade is heeling.	See page 30 on "Heeling the Blade".
	Work is fed too fast.	Slow the feed rate.
	Rip fence is misaligned.	Align the rip fence.
	Wood is warped.	Replace the wood. Always cut with convex side to table surface.
	Spreader is out of alignment.	See "To check and align the spreader/riving knife and saw blade" in the <i>Assembly</i> section.
Wood edges away from rip fence when ripping.	Blade not properly sharpened or set.	Resharpen or set blade.

TROUBLESHOOTING

PROBLEM	CAUSE	SOLUTION
Saw does not make accurate 90° or 45° cuts.	Positive stops inside cabinet need adjusting (Bevel Cuts).	Adjust positive stops.
	Miter gauge is misaligned (Miter Cuts).	Adjust the miter gauge.
Height/bevel adjusting hand-wheel is hard to turn.	Gears or screw post inside cabinet are clogged with saw dust.	Clean the gears or screw post.
Saw does not start.	Motor cord or wall cord is not plugged in.	Plug in motor cord or wall cord.
	Circuit fuse is blown.	Replace circuit fuse.
	Circuit breaker is tripped.	Reset circuit breaker.
	Cord or switch is damaged.	Have the cord or switch replaced at your nearest authorized service center.
Blade makes poor cuts.	Blade is dull or dirty.	Clean, sharpen, or replace blade.
	Blade is wrong type for cut being made.	Replace with correct type.
	Blade is mounted backwards.	Remount blade.
Motor labors in rip cut.	Blade not proper for rip cut.	Change blade; rip blade typically has fewer teeth.

CRAFTSMAN 10 in. TABLE SAW - MODEL NUMBER 315.284610

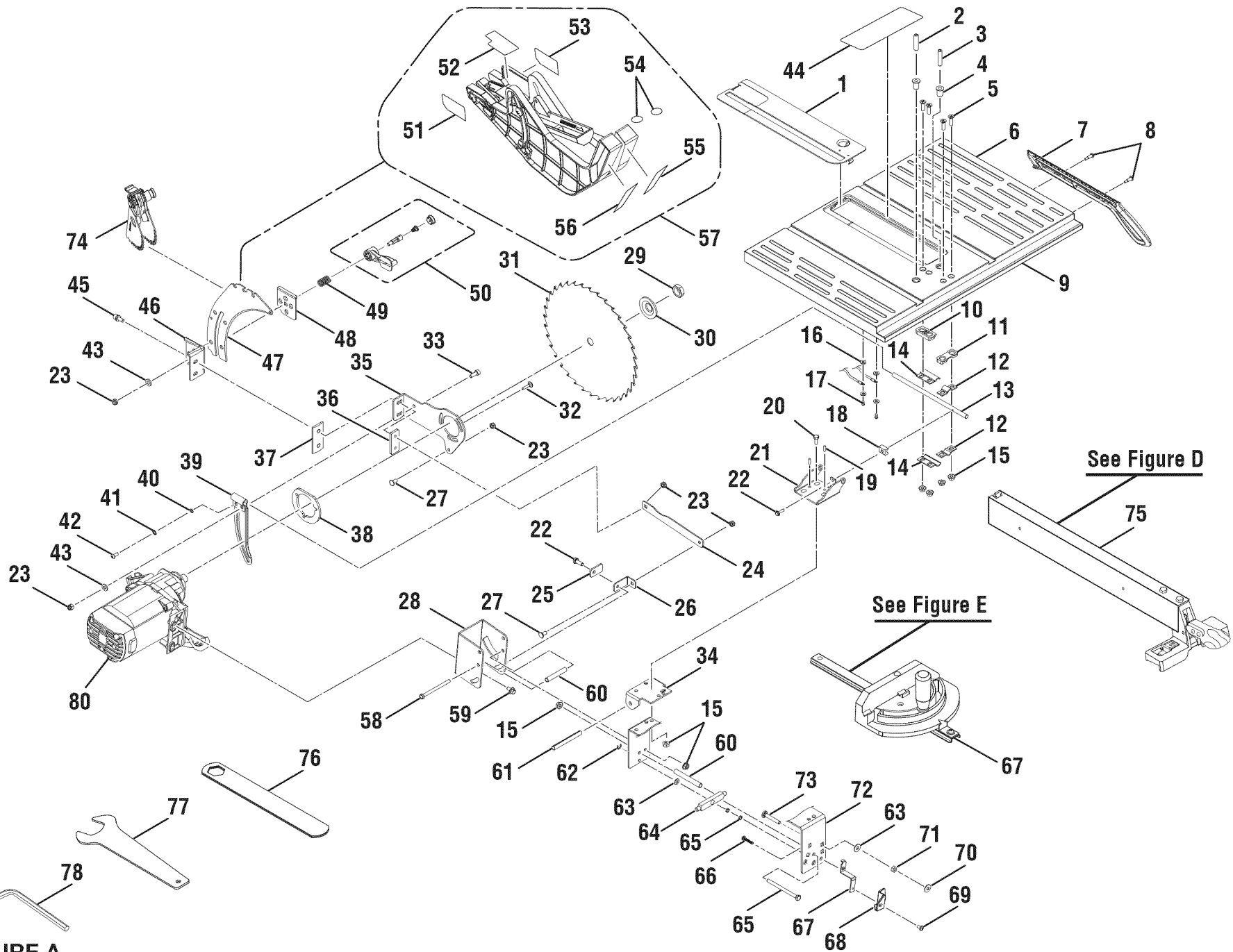

FIGURE A

CRAFTSMAN 10 in. TABLE SAW – MODEL NUMBER 315.284610

The model number will be found on a label attached to the cabinet. Always mention the model number in all correspondence regarding your **10 in. PORTABLE TABLE SAW** or when ordering parts.

PARTS LIST FOR FIGURE A

KEY NO.	PART NUMBER	DESCRIPTION	QTY	KEY NO.	PART NUMBER	DESCRIPTION	QTY
1	089110120001	Throat Plate Assembly	1	29	0101010920	Blade Nut (5/8-18).....	1
2	089015001001	Screw (M8 x 30 mm).....	1	30	0101010302	Blade Washer	1
3	089015001013	Screw (M8 x 35 mm).....	1	31	089110120004	Saw Blade (24 tooth)	1
4	089037007004	Nut (M8)	2	32	089037007017	Screw (M4 x 0.7 mm).....	3
5	410102702	Screw (1/4-20 x 7/8 in., Flat Hd.).....	4	33	089037007018	Screw (M6 x 15 mm).....	1
6	089110120002	Saw Table.....	1	34	080015001439	Middle Bracket.....	1
7	089110120003	Push Stick.....	1	35	089037007019	Lever	1
8	089037007007	Screw (M4, Pan Hd.).....	2	36	089037007020	Clamp Lock.....	1
9	089110120902	Scale Label	1	37	089037007021	Clamp	1
10	089037007008	Rod Bracket.....	1	38	089037007097	Pad.....	1
11	089015001003	Rod Clamp Base.....	1	39	089037007098	Plate Support.....	1
12	0101010303	Strap (Long)	2	40	412011007	Washer (D5 x D12 x 1.5t).....	2
13	089037007009	Rod	1	41	412021005	Lock Washer (D5).....	2
14	089037007010	Short Rod Clamp Base.....	2	42	089037007101	Screw (M5 x 10 mm, Hex Hd.).....	2
15	411062701	Flange Nut (1/4-20).....	4	43	412012701	Washer (D1/4 x D16 x 1t).....	3
16	089110120005	Washer (D4 mm)	5	44	089037007907	Warning Label.....	1
17	410132057	Screw (M4 x 8 mm, Pan Hd.).....	2	45	089037007022	Screw (M6 x 20 mm, Hex Hd.).....	2
18	0101010501	Block	1	46	089037007023	Riving Knife Base.....	1
19	414011001	Spring Pin (D4 x 13 mm).....	2	47	089037007702	Spreader/Riving Knife.....	1
20	410162701	Screw (1/4-20 x 3/4 in., Cheese Hd.).....	3	48	089037007024	Clamp Bracket.....	1
21	0101010304	Upper Pivot Bracket	1	49	089037007096	Spreader/Riving Knife Spring	1
22	089037007011	Screw (M5 x 20 mm, Hex Hd.).....	1	50	089037007709	Riving Knife Handle Assembly.....	1
23	411071001	Lock Nut (M6)	7	51	089110118904	Guard Warning Label (Left).....	1
24	089037007012	Pull Rod	1	52	089110118905	Warning Label (Upper Barrier)	1
25	089037007013	Support Plate.....	1	53	089037007911	Guard Warning Label (Right).....	1
26	089037007014	Mounting Bracket	1	54	089110113913	No Hands Warning Label.....	2
27	089037007015	Bolt.....	2	55	089110118908	Front Blade Guard Warning Label (Right).....	1
28	089037007016	Motor Bracket.....	1	56	089110118909	Front Blade Guard Warning Label (Left)	1

CRAFTSMAN 10 in. TABLE SAW – MODEL NUMBER 315.284610

The model number will be found on a label attached to the cabinet. Always mention the model number in all correspondence regarding your **10 in. PORTABLE TABLE SAW** or when ordering parts.

PARTS LIST FOR FIGURE A

KEY NO.	PART NUMBER	DESCRIPTION	QTY	KEY NO.	PART NUMBER	DESCRIPTION	QTY
57	089037007700	Blade Guard Assembly (Inc. Key Nos. 51-56)	1	70	089037007102	Washer (D6.5 x D20 x 1.6t)	3
58	080015001437	Screw (1/4-20 x 3-1/4 in., Hex Hd.)	2	71	080015001455	Hex Nut (1/4-20)	1
59	410162003	Screw (M6 x 18 mm, Cheese Hd.)	3	72	089037007036	Work Plate.....	1
60	0101010905	Spacer (D9.5 x 68 mm)	2	73	089037007035	Bolt (1/4-20 x 40 mm)	1
61	414011002	Pin (D8 x 90 mm)	1	74	089037007701	Anti-Kickback Pawl Assembly	1
62	089037007029	C-Ring.....	1	75	089110120706	Rip Fence Assembly	1
63	412012701	Washer (D1/4 x D16 x 2t).....	6	76	0101010312	Wrench (Closed End)	1
64	089037007033	Block.....	1	77	0101010313	Wrench (Open End).....	1
65	089037007034	Hex Nut (3/8-16)	2	78	0101140903	Hex Key (M5 x 75 mm)	1
66	089037007031	Screw (M8 x 9.5 mm, Hex Hd.).....	1	Not Shown:			
67	089110120707	Miter Gauge Assembly	1	988000118	Operator's Manual (089037008193)	1	
68	089037007032	Indicator.....	1				
69	089110101066	Screw w/Washer (M4 x 12 mm, Pan Hd.).....	1				

CRAFTSMAN 10 in. TABLE SAW – MODEL NUMBER 315.284610

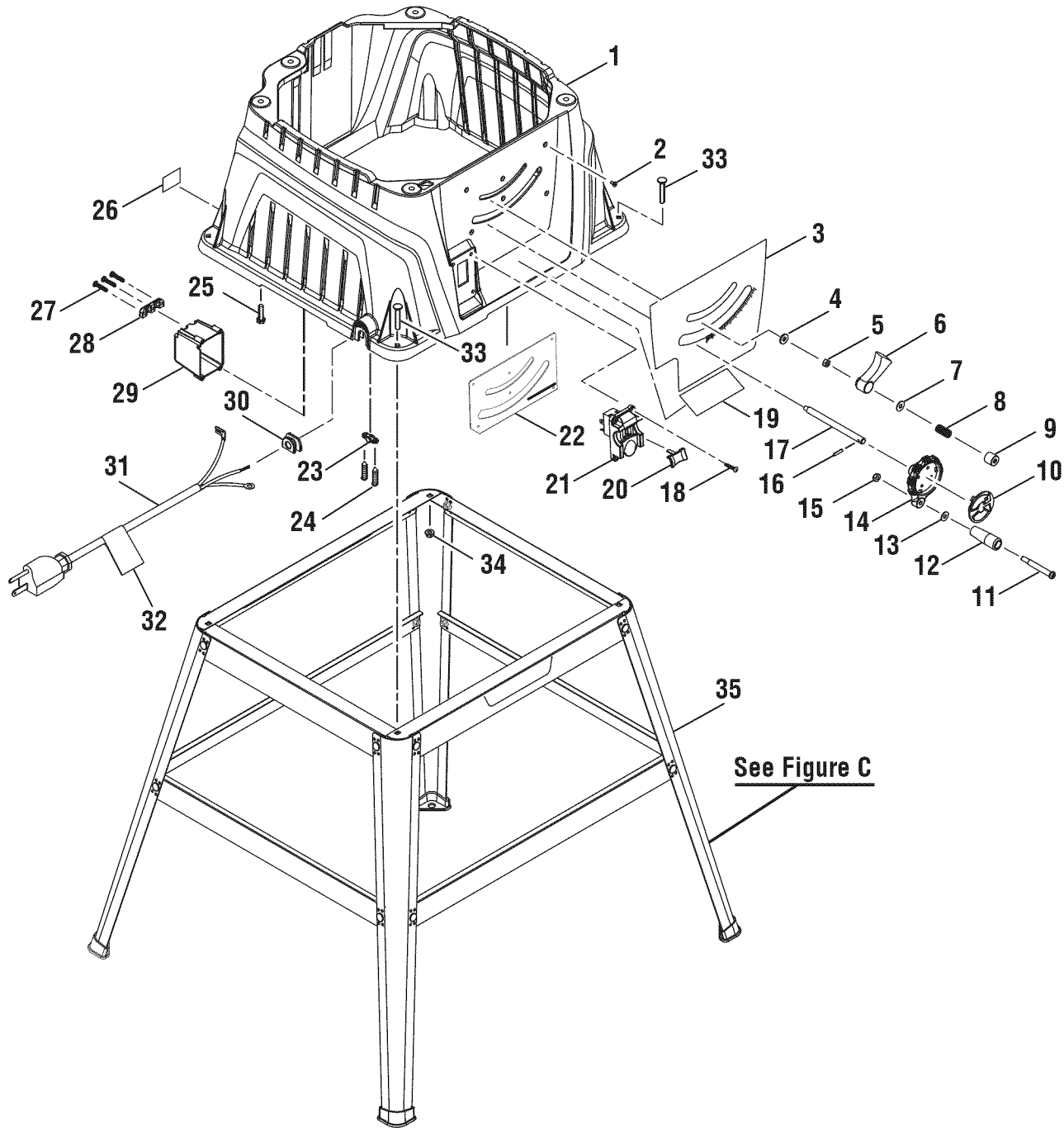

FIGURE B

CRAFTSMAN 10 in. TABLE SAW – MODEL NUMBER 315.284610

The model number will be found on a label attached to the cabinet. Always mention the model number in all correspondence regarding your **10 in. PORTABLE TABLE SAW** or when ordering parts.

PARTS LIST FOR FIGURE B

KEY NO.	PART NUMBER	DESCRIPTION	QTY	KEY NO.	PART NUMBER	DESCRIPTION	QTY
1	089110120006	Cabinet	1	19	089037007901	Warning Label	1
2	080015001473	Screw (M4 x 7 mm, Flat Hd.)	6	20	984406003	Switch Key	1
3	089110120900	Front Panel Label.....	1	21	089110109712	Switch Assembly (Inc. Key No. 20).....	1
4	080015001475	Nylon Washer.....	1	22	089037007044	Plate.....	1
5	080015001455	Hex Nut (1/4-20)	1	23	0101040203	Cord Clamp.....	1
6	089110120007	Lock Lever	1	24	410192002	Screw (M4 x 16 mm, Pan Hd.).....	2
7	412012701	Washer (D1/4 x D16 x 1t).....	2	25	080015001486	Screw (M6 x 25 mm, Cheese Hd.).....	5
8	0101140904	Spring	1	26	089110120901	Data Label.....	1
9	089110120008	Lock Button	1	27	0000120817	Screw (M8 x 19 mm, Pan Hd.).....	3
10	089110120009	Hand Wheel Cap.....	1	28	0131010210	Cord Clamp.....	1
11	0101140203	Screw (Special, Handwheel)	1	29	089037007046	Switch Box	1
12	0152010204	Handle.....	1	30	0121010235	Power Cord Bushing (Grommet).....	1
13	412011712	Washer (D1/4 x D13 x 1.5t).....	1	31	089037007045	Power Cord.....	1
14	089110120010	Height/Bevel Adjusting Handwheel	1	32	089110118910	Warning Label	1
15	411072702	Lock Nut (1/4-20).....	1	33	089037007105	Bolt (1/4-20 x 1-3/8 in.).....	4
16	414011003	Spring Pin (D4 x 16 mm)	1	34	411062701	Flange Nut (1/4-20 x 10 mm).....	4
17	089037007042	Elevating Shaft (3/8-16 x 137 mm)	1	35	089110120708	Stand Assembly (Inc. Key Nos. 1-8, See Figure C)	1
18	410601004	Screw (M4 x 18 mm, Pan Hd.).....	4				

CRAFTSMAN 10 in. TABLE SAW – MODEL NUMBER 315.284610

The model number will be found on a label attached to the cabinet. Always mention the model number in all correspondence regarding your 10 in. PORTABLE TABLE SAW or when ordering parts.

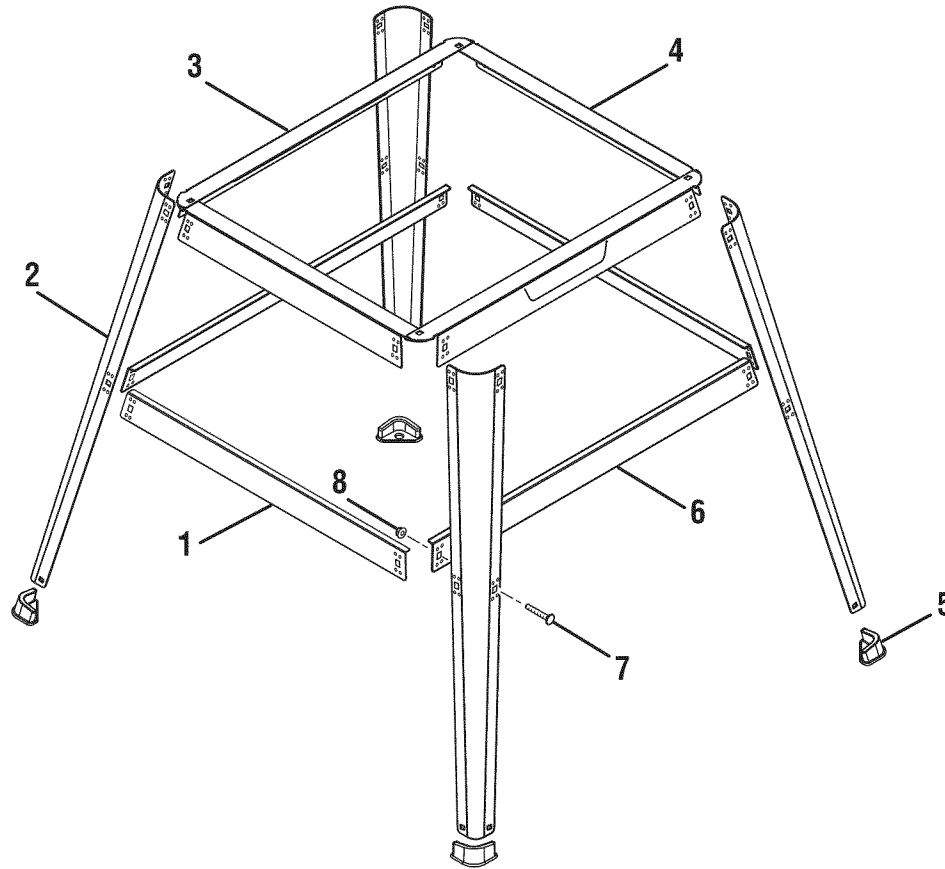

FIGURE C

PARTS LIST FOR FIGURE C

KEY NO.	PART NUMBER	DESCRIPTION	QTY	KEY NO.	PART NUMBER	DESCRIPTION	QTY
1	089037007093	Lower Side Brace	2	5	089037007094	Foot.....	4
2	089037007089	Leg.....	4	6	089037007091	Lower Brace.....	2
3	089110120017	Upper Brace.....	2	7	089037007092	Bolt (1/4-20 x 12 mm)	16
4	089037007090	Upper Side Brace	2	8	411062701	Flange Nut (1/4-20 x 10 mm)	16

CRAFTSMAN 10 in. TABLE SAW – MODEL NUMBER 315.284610

The model number will be found on a label attached to the cabinet. Always mention the model number in all correspondence regarding your 10 in. PORTABLE TABLE SAW or when ordering parts.

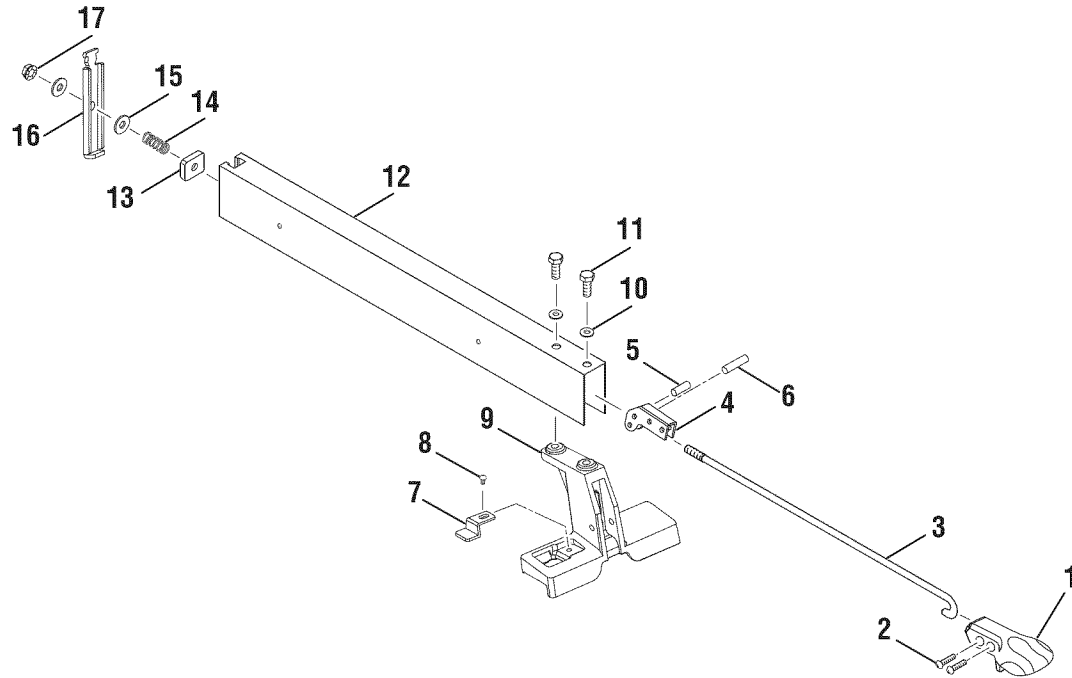

FIGURE D

PARTS LIST FOR FIGURE D

KEY NO.	PART NUMBER	DESCRIPTION	QTY	KEY NO.	PART NUMBER	DESCRIPTION	QTY
1	089110120011	Locking Lever	1	10	412042702	Lock Washer (1/4 in.)	2
2	089037007081	Screw (M8 x 5/8 in.)	2	11	410012701	Screw (1/4-20 x 1/2 in., Hex Hd.)	2
3	089037007082	Lock Rod	1	12	089110120013	Fence	1
4	089037007083	Handle Bar	1	13	0101010211	Block.....	1
5	414011028	Spring Pin (D4 x 10.5 mm).....	1	14	0101010916	Spring	1
6	414011003	Spring Pin (D4 x 20 mm).....	1	15	412012030	Washer (D6.5 x D16 x 1.5t).....	2
7	0101140305	Pointer.....	1	16	089037007085	Rear Clamp.....	1
8	410542702	Screw (5/32-32 x 1/4 in.)	1	17	411072702	Lock Nut (1/4-20).....	1
9	089110120012	Front Block	1				

CRAFTSMAN 10 in. TABLE SAW – MODEL NUMBER 315.284610

The model number will be found on a label attached to the cabinet. Always mention the model number in all correspondence regarding your 10 in. PORTABLE TABLE SAW or when ordering parts.

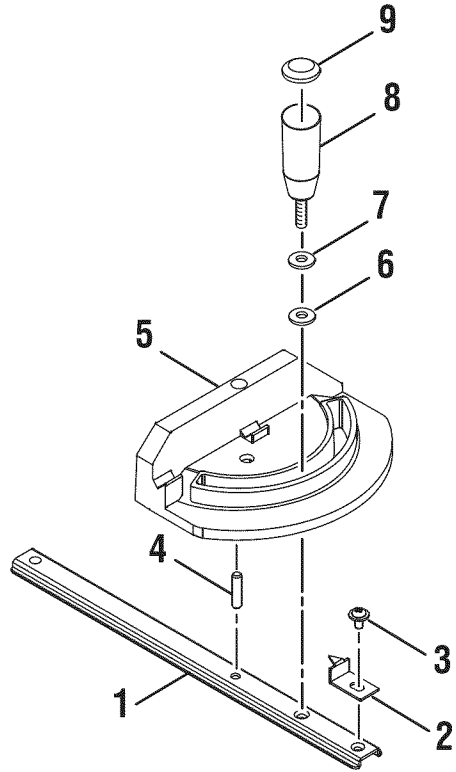

FIGURE E

PARTS LIST FOR FIGURE E

KEY NO.	PART NUMBER	DESCRIPTION	QTY	KEY NO.	PART NUMBER	DESCRIPTION	QTY
1	089015001009	Miter Gauge Rod	1	6	080015001475	Nylon Washer.....	1
2	080015001563	Pointer.....	1	7	412012003	Washer (D6.5 x D16 x 2t)	1
3	410332701	Screw (3/16 in. x 1/4 in.)	1	8	089110120015	Miter Gauge Knob.....	1
4	089015001010	Pin.....	1	9	089110120016	Miter Gauge Cap	1
5	089110120014	Miter Gauge	1				